



Figure similar

SIRIUS soft starter 200-600 V 143 A, 24 V AC/DC Screw terminals
Thermistor input

product brand name	SIRIUS
product category	Hybrid switching devices
product designation	Soft starter
product type designation	3RW50
manufacturer's article number	
<ul style="list-style-type: none"> • of standard HMI module usable 	3RW5980-OHS01
<ul style="list-style-type: none"> • of high feature HMI module usable 	3RW5980-OHF00
<ul style="list-style-type: none"> • of communication module PROFINET standard usable 	3RW5980-OCS00
<ul style="list-style-type: none"> • of communication module PROFIBUS usable 	3RW5980-OCP00
<ul style="list-style-type: none"> • of communication module Modbus TCP usable 	3RW5980-OCT00
<ul style="list-style-type: none"> • of communication module Modbus RTU usable 	3RW5980-OCR00
<ul style="list-style-type: none"> • of communication module Ethernet/IP 	3RW5980-OCE00
<ul style="list-style-type: none"> • of circuit breaker usable at 400 V 	3VA2220-7MN32-0AA0; Type of assignment 1, I _q = 20 kA
<ul style="list-style-type: none"> • of circuit breaker usable at 500 V 	3VA2220-7MN32-0AA0; Type of assignment 1, I _q = 20 kA
<ul style="list-style-type: none"> • of the gG fuse usable up to 690 V 	3NA3244-6; Type of coordination 1, I _q = 65 kA
<ul style="list-style-type: none"> • of full range R fuse link for semiconductor protection usable up to 690 V 	3NE1 227-0; Type of coordination 2, I _q = 65 kA
<ul style="list-style-type: none"> • of back-up R fuse link for semiconductor protection usable up to 690 V 	3NE3 334 -0B; Type of coordination 2, I _q = 65 kA
<ul style="list-style-type: none"> • of line contactor usable up to 480 V 	3RT1055
<ul style="list-style-type: none"> • of line contactor usable up to 690 V 	3RT1055
General technical data	
starting voltage [%]	30 ... 100 %
stopping voltage [%]	50 ... 50 %
start-up ramp time of soft starter	0 ... 20 s
ramp-down time of soft starter	0 ... 20 s
current limiting value [%] adjustable	130 ... 700 %
accuracy class acc. to IEC 61557-12	5 %
certificate of suitability	
<ul style="list-style-type: none"> • CE marking 	Yes
<ul style="list-style-type: none"> • UL approval 	Yes
<ul style="list-style-type: none"> • CSA approval 	Yes
product component is supported	
<ul style="list-style-type: none"> • HMI-Standard 	Yes
<ul style="list-style-type: none"> • HMI-High Feature 	Yes
product feature integrated bypass contact system	Yes
number of controlled phases	2

trip class	CLASS 10A / 10E (preset) / 20E; acc. to IEC 60947-4-2
buffering time in the event of power failure	
• for main current circuit	100 ms
• for control circuit	100 ms
insulation voltage rated value	600 V
degree of pollution	3, acc. to IEC 60947-4-2
impulse voltage rated value	6 kV
blocking voltage of the thyristor maximum	1 800 V
service factor	1
reference code acc. to IEC 81346-2	Q
product function	
• ramp-up (soft starting)	Yes
• ramp-down (soft stop)	Yes
• Soft Torque	Yes
• adjustable current limitation	Yes
• pump ramp down	Yes
• intrinsic device protection	Yes
• motor overload protection	Yes; Full motor protection (thermistor motor protection and electronic motor overload protection)
• evaluation of thermistor motor protection	Yes; Type A PTC or Klixon / Thermoclick
• auto-RESET	Yes
• manual RESET	Yes
• remote reset	Yes; By turning off the control supply voltage
• communication function	Yes
• operating measured value display	Yes; Only in conjunction with special accessories
• error logbook	Yes; Only in conjunction with special accessories
• via software parameterizable	No
• via software configurable	Yes
• PROFInergy	Yes; in connection with the PROFINET Standard communication module
• voltage ramp	Yes
• torque control	No
• analog output	No
Power Electronics	
operational current	
• at 40 °C rated value	143 A
• at 50 °C rated value	128 A
• at 60 °C rated value	118 A
operating voltage	
• rated value	200 ... 600 V
relative negative tolerance of the operating voltage	-15 %
relative positive tolerance of the operating voltage	10 %
operating power for 3-phase motors	
• at 230 V at 40 °C rated value	37 kW
• at 400 V at 40 °C rated value	75 kW
• at 500 V at 40 °C rated value	90 kW
Operating frequency 1 rated value	50 Hz
Operating frequency 2 rated value	60 Hz
relative negative tolerance of the operating frequency	-10 %
relative positive tolerance of the operating frequency	10 %
adjustable motor current	
• at rotary coding switch on switch position 1	68 A
• at rotary coding switch on switch position 2	73 A
• at rotary coding switch on switch position 3	78 A
• at rotary coding switch on switch position 4	83 A
• at rotary coding switch on switch position 5	88 A
• at rotary coding switch on switch position 6	93 A
• at rotary coding switch on switch position 7	98 A
• at rotary coding switch on switch position 8	103 A

<ul style="list-style-type: none"> • at rotary coding switch on switch position 9 • at rotary coding switch on switch position 10 • at rotary coding switch on switch position 11 • at rotary coding switch on switch position 12 • at rotary coding switch on switch position 13 • at rotary coding switch on switch position 14 • at rotary coding switch on switch position 15 • at rotary coding switch on switch position 16 • minimum 	108 A
	113 A
	118 A
	123 A
	128 A
	133 A
	138 A
	143 A
	68 A
minimum load [%]	15 %; Relative to smallest settable le
power loss [W] for rated value of the current at AC	
<ul style="list-style-type: none"> • at 40 °C after startup • at 50 °C after startup • at 60 °C after startup 	23 W
	19 W
	16 W
power loss [W] at AC at current limitation 350 %	
<ul style="list-style-type: none"> • at 40 °C during startup • at 50 °C during startup • at 60 °C during startup 	1 336 W
	1 134 W
	1 007 W
type of the motor protection	Electronic, tripping in the event of thermal overload of the motor
Control circuit/ Control	
type of voltage of the control supply voltage	AC/DC
<ul style="list-style-type: none"> • control supply voltage at AC at 50 Hz rated value • control supply voltage at AC at 60 Hz rated value 	24 V
	24 V
relative negative tolerance of the control supply voltage at AC at 50 Hz	-20 %
relative positive tolerance of the control supply voltage at AC at 50 Hz	20 %
relative negative tolerance of the control supply voltage at AC at 60 Hz	-20 %
relative positive tolerance of the control supply voltage at AC at 60 Hz	20 %
control supply voltage frequency	50 ... 60 Hz
relative negative tolerance of the control supply voltage frequency	-10 %
relative positive tolerance of the control supply voltage frequency	10 %
<ul style="list-style-type: none"> • control supply voltage at DC rated value 	24 V
relative negative tolerance of the control supply voltage at DC	-20 %
relative positive tolerance of the control supply voltage at DC	20 %
control supply current in standby mode rated value	160 mA
holding current in bypass operation rated value	360 mA
locked-rotor current at close of bypass contact maximum	7.6 A
inrush current peak at application of control supply voltage maximum	3.3 A
duration of inrush current peak at application of control supply voltage	12.1 ms
design of the overvoltage protection	Varistor
design of short-circuit protection for control circuit	4 A gG fuse (I _{cu} =1 kA), 6 A quick-acting fuse (I _{cu} =1 kA), C1 miniature circuit breaker (I _{cu} = 600 A), C6 miniature circuit breaker (I _{cu} = 300 A); Is not part of scope of supply
Inputs/ Outputs	
number of digital inputs	1
number of inputs for thermistor connection	1; Type A PTC or Klixon / Thermoclick
number of digital outputs	3
<ul style="list-style-type: none"> • not parameterizable 	2
digital output version	2 normally-open contacts (NO) / 1 changeover contact (CO)
number of analog outputs	0
Installation/ mounting/ dimensions	

mounting position	with vertical mounting surface +/-90° rotatable, with vertical mounting surface +/- 22.5° tiltable to the front and back
fastening method	screw fixing
height	198 mm
width	120 mm
depth	249 mm
required spacing with side-by-side mounting	
• forwards	10 mm
• backwards	0 mm
• upwards	100 mm
• downwards	75 mm
• at the side	5 mm
weight without packaging	3.2 kg
Connections/ Terminals	
type of electrical connection	
• for main current circuit	busbar connection
• for control circuit	screw-type terminals
width of connection bar maximum	25 mm
wire length for thermistor connection	
• with conductor cross-section = 0.5 mm ² maximum	50 m
• with conductor cross-section = 1.5 mm ² maximum	150 m
• with conductor cross-section = 2.5 mm ² maximum	250 m
type of connectable conductor cross-sections	
• for main contacts for box terminal using the front clamping point solid	16 ... 120 mm ²
• for main contacts for box terminal using the front clamping point finely stranded with core end processing	16 ... 120 mm ²
• for main contacts for box terminal using the front clamping point finely stranded without core end processing	10 ... 120 mm ²
• for main contacts for box terminal using the front clamping point stranded	16 ... 70 mm ²
• at AWG cables for main contacts for box terminal using the front clamping point	6 ... 250 kcmil
• for main contacts for box terminal using the back clamping point solid	16 ... 120 mm ²
• at AWG cables for main contacts for box terminal using the back clamping point	6 ... 250 kcmil
• for main contacts for box terminal using both clamping points solid	max. 1x 95 mm ² , 1x 120 mm ²
• for main contacts for box terminal using both clamping points finely stranded with core end processing	max. 1x 95 mm ² , 1x 120 mm ²
• for main contacts for box terminal using both clamping points finely stranded without core end processing	max. 1x 95 mm ² , 1x 120 mm ²
• for main contacts for box terminal using both clamping points stranded	max. 2x 120 mm ²
• for main contacts for box terminal using the back clamping point finely stranded with core end processing	16 ... 120 mm ²
• for main contacts for box terminal using the back clamping point finely stranded without core end processing	10 ... 120 mm ²
• for main contacts for box terminal using the back clamping point stranded	16 ... 120 mm ²
type of connectable conductor cross-sections	
• at AWG cables for main current circuit solid	4 ... 250 kcmil
• for DIN cable lug for main contacts stranded	16 ... 95 mm ²
• for DIN cable lug for main contacts finely stranded	25 ... 120 mm ²
type of connectable conductor cross-sections	
• for control circuit solid	1x (0.5 ... 4.0 mm ²), 2x (0.5 ... 2.5 mm ²)

<ul style="list-style-type: none"> for control circuit finely stranded with core end processing at AWG cables for control circuit solid 	1x (0.5 ... 2.5 mm ²), 2x (0.5 ... 1.5 mm ²)
wire length <ul style="list-style-type: none"> between soft starter and motor maximum at the digital inputs at AC maximum 	800 m 1 000 m
tightening torque <ul style="list-style-type: none"> for main contacts with screw-type terminals for auxiliary and control contacts with screw-type terminals 	10 ... 14 N·m 0.8 ... 1.2 N·m
tightening torque [lbf·in] <ul style="list-style-type: none"> for main contacts with screw-type terminals for auxiliary and control contacts with screw-type terminals 	89 ... 124 lbf·in 7 ... 10.3 lbf·in
Ambient conditions	
installation altitude at height above sea level maximum	5 000 m; Derating as of 1000 m, see manual
<ul style="list-style-type: none"> ambient temperature during operation ambient temperature during storage and transport 	-25 ... +60 °C; Please observe derating at temperatures of 40 °C or above -40 ... +80 °C
environmental category <ul style="list-style-type: none"> during operation acc. to IEC 60721 during storage acc. to IEC 60721 during transport acc. to IEC 60721 	3K6 (no ice formation, only occasional condensation), 3C3 (no salt mist), 3S2 (sand must not get into the devices), 3M6 1K6 (only occasional condensation), 1C2 (no salt mist), 1S2 (sand must not get inside the devices), 1M4 2K2, 2C1, 2S1, 2M2 (max. fall height 0.3 m)
EMC emitted interference	acc. to IEC 60947-4-2: Class A
Communication/ Protocol	
communication module is supported <ul style="list-style-type: none"> PROFINET standard EtherNet/IP Modbus RTU Modbus TCP PROFIBUS 	Yes Yes Yes Yes Yes
UL/CSA ratings	
manufacturer's article number <ul style="list-style-type: none"> of circuit breaker <ul style="list-style-type: none"> usable for Standard Faults at 460/480 V according to UL of the fuse <ul style="list-style-type: none"> usable for Standard Faults up to 575/600 V according to UL usable for High Faults up to 575/600 V according to UL 	Siemens type: 3VA5225, max. 250 A; I _q = 10 kA Type: Class RK5 / K5, max. 350 A; I _q = 10 kA Type: Class J, max. 350 A; I _q = 100 kA
operating power [hp] for 3-phase motors <ul style="list-style-type: none"> at 200/208 V at 50 °C rated value at 220/230 V at 50 °C rated value at 460/480 V at 50 °C rated value at 575/600 V at 50 °C rated value 	40 hp 40 hp 100 hp 125 hp
Safety related data	
protection class IP on the front acc. to IEC 60529	IP00; IP20 with cover
touch protection on the front acc. to IEC 60529	finger-safe, for vertical contact from the front with cover
ATEX	
certificate of suitability <ul style="list-style-type: none"> ATEX IECEX 	Yes Yes
hardware fault tolerance acc. to IEC 61508 relating to ATEX	0
PF_{Davg} with low demand rate acc. to IEC 61508 relating to ATEX	0.09
PF_{HD} with high demand rate acc. to EN 62061 relating	0.000009 1/h

to ATEX	
Safety Integrity Level (SIL) acc. to IEC 61508 relating to ATEX	SIL1
T1 value for proof test interval or service life acc. to IEC 61508 relating to ATEX	3 y

Certificates/ approvals

General Product Approval	For use in hazardous locations
--------------------------	--------------------------------



Declaration of Conformity	Test Certificates	other
---------------------------	-------------------	-------



[Miscellaneous](#)

[Type Test Certificates/Test Report](#)

[Type Test Certificates/Test Report](#)

[Confirmation](#)

[Confirmation](#)

Further information

Information- and Downloadcenter (Catalogs, Brochures,...)

<https://www.siemens.com/ic10>

Industry Mall (Online ordering system)

<https://mall.industry.siemens.com/mall/en/en/Catalog/product?mlfb=3RW5055-6TB05>

Cax online generator

<http://support.automation.siemens.com/WW/CAXorder/default.aspx?lang=en&mlfb=3RW5055-6TB05>

Service&Support (Manuals, Certificates, Characteristics, FAQs,...)

<https://support.industry.siemens.com/cs/ww/en/ps/3RW5055-6TB05>

Image database (product images, 2D dimension drawings, 3D models, device circuit diagrams, EPLAN macros, ...)

http://www.automation.siemens.com/bilddb/cax_de.aspx?mlfb=3RW5055-6TB05&lang=en

Characteristic: Tripping characteristics, I²t, Let-through current

<https://support.industry.siemens.com/cs/ww/en/ps/3RW5055-6TB05/char>

Characteristic: Installation altitude

<http://www.automation.siemens.com/bilddb/index.aspx?view=Search&mlfb=3RW5055-6TB05&objecttype=14&gridview=view1>

Simulation Tool for Soft Starters (STS)

<https://support.industry.siemens.com/cs/ww/en/view/101494917>

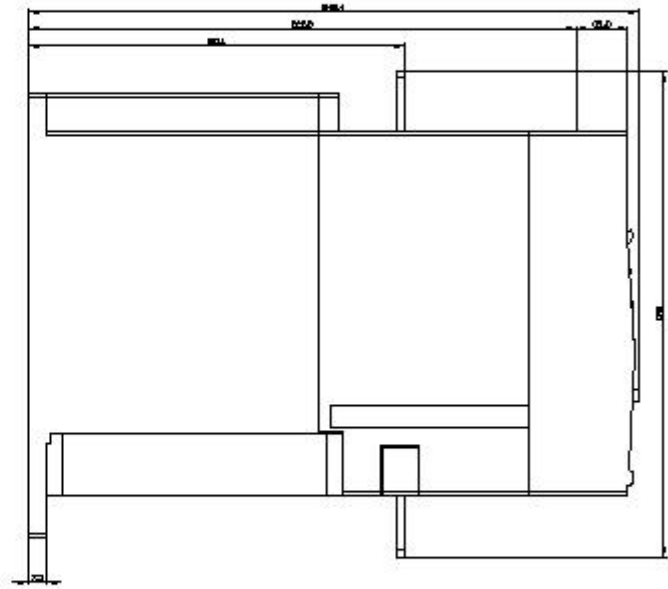
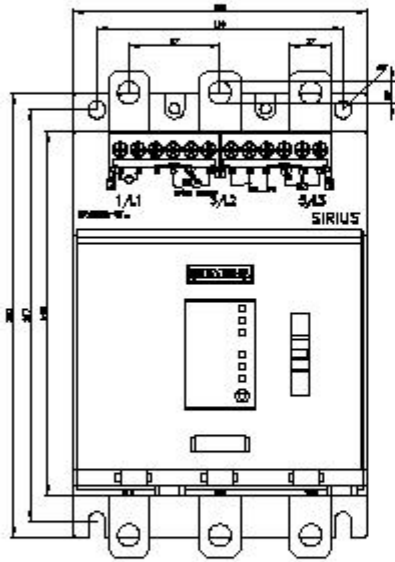

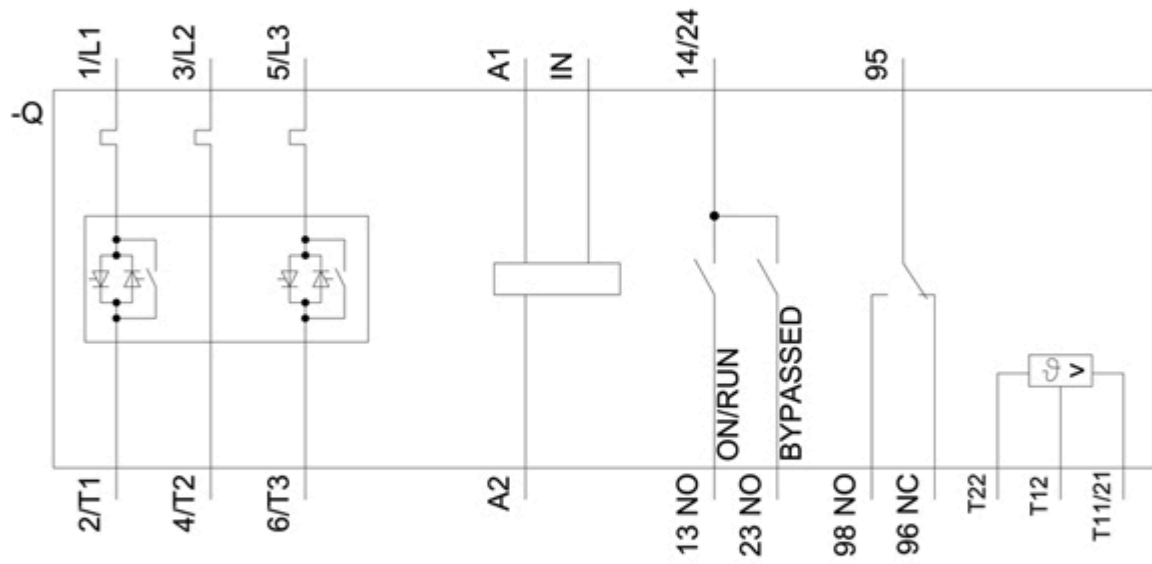

last modified:

12/15/2020 