

N 502/02 Combi switching actuator
8x IN AC/DC 12...230 V, 8x OUT AC 230 V, 16A AC1

5WG1 502-1AB02

Product and function description



The N 502/02 combi switching actuator is a N-type device for DIN-rail mounting with 8 inputs for 12-230V AC/DC and 8 switching outputs (relay contacts) for 230V AC, 16A (at a resistive load).

The device can be used in the as delivered state without a bus line connected and without prior setting up with the Engineering Tool Software (ETS). It can be operated with each output acting as a remote-control relay (mode preset at the factory) or as a timer.

In the as delivered state, the inputs act directly on the outputs, i.e. input "a" acts directly on output "A", input "b" directly on output "B", etc. To switch an output via the corresponding input, it must be connected to a conventional pushbutton, which switches e.g. AC 230V to the input while pressing the button (see connection example). If an output is to be switched from several points, then a number of pushbuttons can be connected in parallel to the corresponding input.

Each output can be switched on or off in "Direct mode" via the corresponding button on the front panel of the device (see figure 1) by a toggle function. To do this, first switch-on this mode by pressing the "Direct mode" key (yellow LED for direct mode indication is switched on) and then press the button assigned to the output to be switched. The relevant switching status of the outputs is displayed by the red LEDs integrated in the buttons. If, after direct switching of an output, direct mode is not ended by another press of the "Direct mode" button, then this is done automatically 15 minutes after the final press of one of the buttons on the front panel.

Application program

The combi switching actuator N 502/02 needs the application program "25 A8 8x BI / 8x BO 981502" which has to be configured and loaded with ETS3.

With the N 502/02 combi switching actuator connected to the bus line, the behaviour of each input and output can be set with the ETS. Each output can then be switched not only directly via a button connected to an input, but also via bus pushbuttons connected to the bus. A pushbutton connected to an input of the N 502/02 can then switch the corresponding output directly and via the bus even other outputs of other actuators. Inputs and outputs can then also be operated independently (decoupled) of each other. Each input can be configured and used like an input of a binary input device and each output like an output of a switch actuator.

Connection example

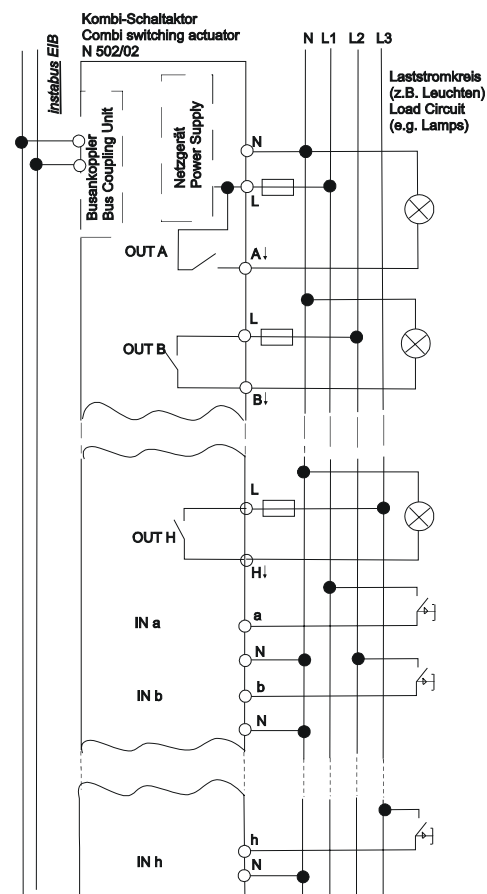

N 502/02 Combi switching actuator
8x IN AC/DC 12...230 V, 8x OUT AC 230 V, 16A AC1

5WG1 502-1AB02

Installation notes

- The device can be used for permanent installation in dry interior rooms and for insertion in control cabinets or small distribution boards.



DANGER

- The device must only be installed and commissioned by an authorized professional electrician.
- Unoccupied sections of DIN rail with data rail inserted must be protected with the cover 5WG1 192-8AA01.
- When connecting the device, care should be taken that the device can be isolated from the mains.
- The device must not be opened.
- When planning and installing electrical equipment the relevant guidelines, regulations and specifications of the respective country must be considered.

Technical data

Power Supply

- Bus voltage: via bus line
- Bus current: 5 mA (only half a standard bus load !)
- Electronics:
 - integrated power supply unit for AC 230V, +10% / -15 %, 50/60 Hz
 - Power supply connection: 2-pole (**N, L for output A**)
 - Power consumption: max. 2.0 W

Inputs

- 8 inputs (each input can be connected to any phase L1, L2 or L3 or a FELV signal)
- Input voltage: AC/DC 12 V ... 230 V
 ($U_{in} = 0...2$ V: voltage not present = log. 0;
 $U_{in} \geq 9$ V: voltage present = log. 1)
Note: For DC voltage the negative pole should be connected in each case to the terminal designated "N".
- Input current:
 at max. AC 253 V: typically 1.5 mA (RMS)
 at max. DC 253 V: typically 3.0 mA
- Input signal delay:
 - at rising edge of input signal:
 max. 60 ms for DC
 max. 100 ms for AC
 - at falling edge of input signal:
 max. 140 ms for DC
 max. 100 ms for AC
- Input signal on-time:
 at least 60 ms at DC, at least 100 ms at AC
- Input signal off-time:
 at least 140 ms at DC, at least 100 ms at AC
- max. detectable switching frequency: 5 Hz

- Input function: can be selected
- Max. length of connecting cable: 100 m

Outputs

- 8 switching outputs (relay contacts), of which outputs B...H with potential free relay contacts:
 - rated voltage AC 230V, 50/60 Hz
 - rated current 16A (with resistive load)

Connections

- Power supply connection, inputs and outputs:
 - Plug-in terminals, insulation strip length 9...10 mm
- The following lead cross-sections are permitted:
 - 0.5 ... 2.5 mm² single-core
 - 0.5 ... 1.5 mm² finely stranded, with connector sleeve
 - 1.5 mm² finely stranded, untreated (max. ampacity then only 6 A !)
- Each phase conductor connected to the N 502/02 is to be fused with a circuit-breaker of characteristic B or C for a max. rated current of 16A!
- Bus line:
 - Pressure contacts on data rail,
 - Screw-less bus terminal, 0.6 ... 0.8 mm Ø single-core, insulation strip length 5 mm

Mechanical Specifications

- Housing: plastic
- Dimensions: DIN rail mounted device with N-system dimensions, width 8 module units (1 MU = 18 mm)
- Weight: approx. 490 g
- Fire load: approx. 6450 kJ
- Installation: Snap-on mounting on DIN rail EN 60715-TH35-7.50

Electrical Safety

- Degree of pollution (according to IEC 60664-1): 2
- Type of protection (according to EN 60529): IP 20
- Over-voltage category (according to IEC 60664-1): III
- Bus: safety extra-low voltage SELV DC 24 V
- Device complies with: EN 50428

EMC requirements

- Complies with EN 50428

Environmental Conditions

- Climatic withstand capability: EN 50090-2-2
- Ambient temperature in operation: - 5 ... + 45 °C
- Storage temperature: - 25 ... + 70 °C
- Relative humidity (non-condensing): 5% to 93%

Approval mark

- KNX *EIB*

CE mark

- In accordance with the EMC guideline (residential and functional buildings), low voltage guideline

N 502/02 Combi switching actuator
8x IN AC/DC 12...230 V, 8x OUT AC 230 V, 16A AC1

5WG1 502-1AB02

Position and function of the display and operating elements

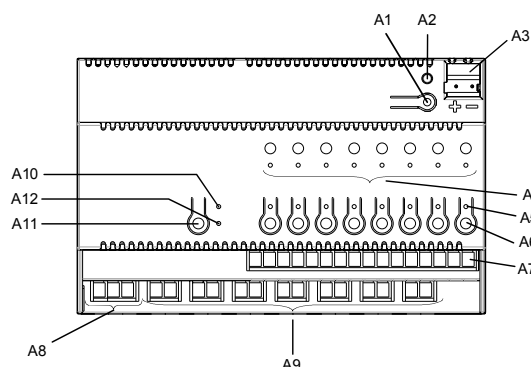

Figure 1: Position of the display and operating elements

- A1 Key for switching between normal mode and addressing mode for transferring the physical address.
- A2 LED for indicating normal mode (LED Off) or addressing mode (LED On); it extinguishes automatically after transferring the physical address
- A3 Plug for bus connection terminal
- A4 LEDs (red) for status indication of inputs a to h
- A5 LEDs (red) for status indication of outputs A to H
- A6 Buttons for direct switching of outputs A to H
- A7 Terminals for inputs a to h
- A8 Terminals for neutral line (N), phase conductor (L) (for power supply to electronics) and output A
- A9 Terminals for outputs B to H
- A10 LED (green) to indicate the operating voltage
- A11 Button to switch direct mode on/off
- A12 LED (yellow) to indicate "Direct mode = ON"

Change of operation mode of an output without ETS

If an output operated previously as "remote-control relay" shall be operated as a "timer", then direct mode is to be switched-on first by pressing the "Direct mode" button (see figure 1). Next, after the yellow "Direct mode" LED is switched-on, the button for direct switching of an output is to be held down for approx. 5 seconds, until the LED integrated in the button flashes slowly (at approx. 0.5 Hz). If the button is then released and not operated within the next 3 seconds, then the LED extinguishes, and the output works as a "timer" with an on-time of 5 minutes. If an on-time other than 5 minutes is wanted, then the button must be pressed again within 3 seconds after releasing it. Pressing the button again leads to an on-time of 1 minute. Pressing the button again within 3 seconds after the previous release leads to the on-time being extended by a further minute, i.e. the number of times the button is pressed equals the switching-on time in minutes (max.

possible is 60 minutes). The first fresh press on the button when the LED is flashing ends this. Instead, the LED is then switched-on for the duration of each button press respectively. If the button is not pressed again within 3 seconds of an earlier press, then the switching-on time setting ends.

Vice versa, if an output operating as a "timer" shall be changed to operating as a "remote-control relay" then, after switching-on direct mode, the button for direct switching of the output is to be held down for approx. 8 seconds, until the LED integrated in the button flashes quickly (at approx. 1 Hz). After 3 seconds, the flashing of the LED ends and the output is then reset to "remote-control relay" mode.

Installation and wiring

General description

The DIN rail mounted device in N-system dimensions (width 8 module units) can be inserted in N-system distribution boards, surface- or flush-mounted and wherever DIN rails according to EN 60715-TH35-7.5 are present.

Installing the DIN rail mounted device (Figure 2)

- Suspend the DIN rail mounted device (B 1) on the DIN rail (B2) and
- Rotate the DIN rail mounted device (B1) backwards until the slide switch audibly clicks into position.

Dismantling the DIN rail mounted device (Figure 2)

- Press the slide switch (C3) downwards with a screwdriver and
- Remove the DIN rail mounted device (C1) from the DIN rail (C2) with a swivel action.

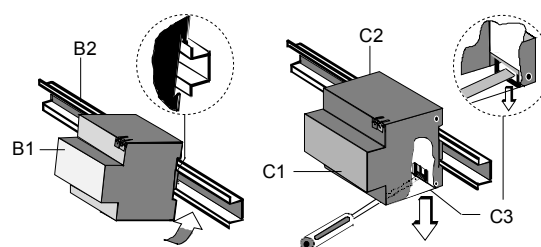

Figure 2: Installing / dismantling the device

**N 502/02 Combi switching actuator
8x IN AC/DC 12...230 V, 8x OUT AC 230 V, 16A AC1**

5WG1 502-1AB02

Removing the bus terminal (Figure 3)

- The bus terminal is located on the top of the device (D1).
- The bus terminal (D2) consists of two sections (D2.1, D2.2) each with four terminal contacts. Care should be taken not to damage the two test sockets (D2.3) either by accidentally trying to put in the bus cable or with the screwdriver (when trying to remove the bus terminal).
- Carefully insert the screwdriver into the wire entry slot underneath the bus terminal (D2) and pull the bus terminal (D2) forwards out of the device (D1).

Note: Care should be taken as there is a risk of shorting the device!

Attaching the bus terminal (Figure 3)

- Place the bus terminal in the guide slot and press the bus terminal (D2) backwards until it reaches the stop.

Connecting the bus cable (Figure 3)

- The bus terminal (D2) is suitable for single-core conductors with 0.6... 0.8 mm Ø.
- Strip approx. 5 mm of insulation from the conductor (D2.4), plug in the terminal (D2) (red = +, black = -).

Disconnecting the bus cable (Figure 3)

- Remove the bus terminal (D2) and the conductor (D2.4) out of the bus cable by rotating it backwards and forwards.

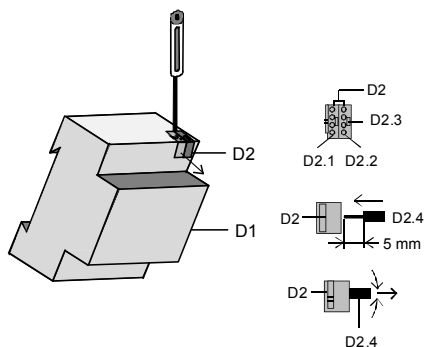

Figure 3: Attaching / removing the bus terminal

Connecting mains voltage, load circuits and inputs

- The connections are designed with plug-in technology.
- Strip approx. 9...10 mm of insulation from the conductors and slide them in the respective terminal.

Mounting the insulating cap

If the device is to be mounted on a DIN rail without a data rail, then the contact system must be covered using the supplied insulating cap.

Removing the locating clamp (Figure 4)

- The locating clamp (E3) encloses the contact system (E2) on the rear of the device (E1).
- Insert the screwdriver between the DIN rail mounted device (E1) and the locating clamp (E3) and remove the clamp.

Clipping on the insulating cap (Figure 4)

- Place the insulating cap (E4) on the contact system and press so that it snaps into place.

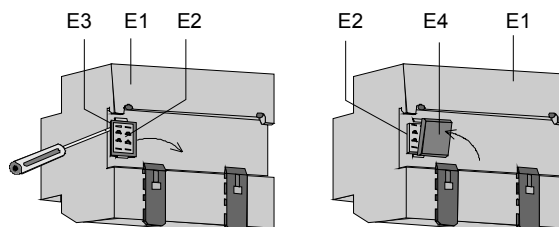
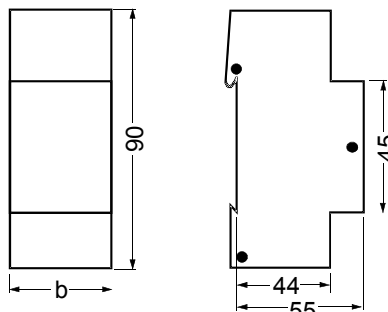

Figure 4: Covering the contact system

Dimension drawing

Dimensions in mm.



b = 8 module units

1 module unit (MU) = 18 mm

General notes

- The operating instructions must be handed over to the client.
- A faulty device shall be sent with a Return Good Note for Service provided by the appropriate Siemens sales office to the following address:
SIEMENS AG, Siemensstr. 10, D-93055 Regensburg
- If you have further questions concerning the product please contact our technical support:
☎ +49 (0) 180 50 50-222
(0,14 €/min. from the German landline network, deviating mobile communications prices are possible)
☎ +49 (0) 180 50 50-223
E-Mail: support.automation@siemens.com
✉ www.siemens.com/automation/support-request