

Desigo™ Room Automation

## Compact room automation stations, BACnet/IP and BACnet/SC, AC 24 V

DXR2.E12P.., DXR2.E12PX.., DXR2.E18..

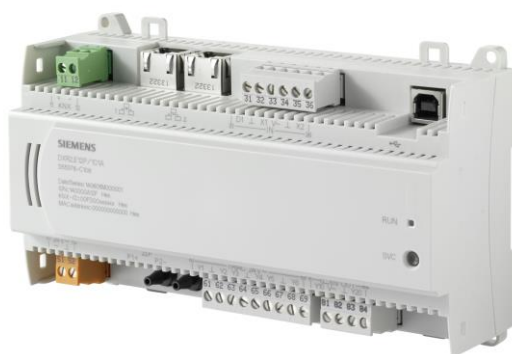

### For building with increased demands placed on functionality and flexibility in Room Automation and VAV applications.

- Compact, programmable room automation stations for HVAC, lighting, and shading
- BACnet/IP communication (BTL certified)
- BACnet Secure Connect communication
- KNX PL-Link bus to connect sensors, actuators, and operator units (including bus power)
- 2 port Ethernet switch
- USB interface
- Operating voltage AC 24 V
- Mounted on standard DIN rails or on the wall
- Plug-in terminal blocks

### Programmable

The DXR2... room automation stations provide the infrastructure for system and application-specific functions and can be programmed.

### Compact series

The compact build permits mounting in narrow spaces and on standardized rails, and is particularly well suited for compact panels or plants with integrated panel.

### Plug-in terminal blocks

Plug-in terminal blocks to easily exchange room automation stations.

- Room automation applications combining multiple disciplines (HVAC, lighting, shading) into one comprehensive solution. Desigo™ room automation offers the highest degree of flexibility for energy-optimized solutions without sacrificing on comfort.
- Room automation applications can be extended with lighting and blinds applications via the KNX PL-Link.

### Preinstalled applications

- Variable (VAV) and constant (CAV) air volume or variable air volume with a serial or parallel fan powered box
  - with 2-stage electric heating
  - with hot water
  - with hot water and flow temperature control
- Fan coil: Cooling or heating with heat pump, outside air control
  - Single stage, multi-stage, or variable speed fan
  - Single stage, multi-stage, or variable speed compressor
  - Internal or external reversing valve
  - Geothermal or water circuit source
  - Optional hot gas reheater
  - Optional electric (staged or modulating) or hot water reheater or hot gas reheater
- Fan coil: Cooling or heating, cooling and heating (2-pipe) or cooling/heating (4-pipe), supply air minimum limitations, outside air control
- Dual duct variable air volume (VAV)
  - Cold air duct, hot air duct with configurable ventilation delivery
  - Dual duct, dedicated configurable ventilation duct with hot water or electric heating coils
  - Dual duct with constant volume option
- Chilled beam active or passive cooling (2-pipe) or cooling/heating (2-pipe) or cooling/heating (4-pipe)
- Radiant ceiling: Cooling, cooling and heating (2-pipe) or cooling/heating (4-pipe)
- Radiator: Hot water, steam (2-pipe or 4-pipe) or electric stage controlled
- Lighting: Up to 4 different zones
- Blinds: 1 or 2 motors

## Application options

- Separate temperature and volume setpoints for all 4 operating modes
- Single-stage or variable ventilation control (fan powered box)
- Chilled water and hot water valve (2-pipe or 4-pipe)
- Extract air flow acquisition and control

## Functions

The selected application and its parameters as well as input and output configuration determine the room automation station's functionality.

A detailed description of functionality is available in the ABT (Automation Building Tool) online help.

## Communication

- 2-Port Ethernet switch for cost-effective cabling via line topology.
- USB connection for service and commissioning, firmware download, and LAN access.
- The following functions are available with the KNX PL-Link bus:
  - Communication with room operator units, switches, sensors, actuators, and luminaires.
  - Plug-and-play connection of Siemens field devices with KNX PL-Link.
  - Integration of common devices using KNX S-Mode (ETS engineering required).

## LED indication

LED	Color	Activity	Function
RUN	Green	Steady ON	Device is ready for operation
		Steady OFF	Device is not powered
		Regular flashing	Start-up or the program is stopped
	Red	Steady OFF	OK
		Steady ON	Program error Communications error (KNX PL-Link) Hardware fault
		Rapid flashing	Wrong or corrupt software No application loaded
		Blinking per wink command	Physical device identification

SVC (Service button)	--	Short press	Physical identification on the network
	--	Factory reset	

1. Power off the device.
2. Power on the device.
3. Wait until the RUN LED lights up and turns off again, then press the Service button.
4. Keep the Service button pressed until the RUN LED lights up, then release the button. The device restarts.
5. Wait until the device has fully started – unconfigured (green RUN LED on, flashes red)

## Technical design

### Power supply

The power supply provides controlled voltages for inputs and outputs. The room automation stations also supply AC 24 V field supply (DXR2..18, DC 24 V too). The supply is located in the device to simplify wiring and diagnostics.

The processor controls the power supply. This ensures clean conditions for field devices connected to the I/Os during startup, shutdown, and undervoltage.

### Bus power supply

The room automation station includes the bus power for KNX PL-Link. The bus power is switched on by default, but can be switched off via web interface or configuration in the Automation Building Tool (ABT).

The internal KNX PL-Link supply cannot be operated parallel to external power supplies. The internal KNX PL-Link power must be switched off during the engineering phase for external power. This is typically the case if the 50 mA from the internal supply is not enough to supply all devices connected on the KNX PL-Link bus.

## Type summary

The devices are supplied without terminal covers. The terminal covers must be ordered separately. See **Accessories**.

### Order numbers: World (excluding the U.S. and Canada) Individual packages

Type	Stock number	Applications	Inputs	Outputs
DXR2.E12P-102A (Version with 30 data points)	S55376-C108	Variable air volume, dual duct VAV, fan-powered box, radiant ceiling, radiator, 4 luminaires & 2 blinds	1 DI, 2 UI, ΔP sensor	6 Triacs, 2 AO
DXR2.E12PX-102A (Version with 60 data points)	S55376-C143	Variable air volume, dual duct VAV, fan-powered box, radiant ceiling, radiator, 4 luminaires & 2 blinds	1 DI, 2 UI, ΔP sensor	6 Triacs, 2 AO
DXR2.E18-101A	S55376-C107	Fan coil, dual duct VAV, radiant ceiling, radiator, 4 luminaires & 2 blinds	2 DI, 4 UI	8 Triacs, 4 AO
DXR2.E18-102A	S55376-C128	Variable air volume, fan-powered box, radiant ceiling, radiator, 4 luminaires & 2 blinds	2 DI, 4 UI	8 Triacs, 4 AO

**Order numbers: World (excluding the U.S. and Canada)  
Bulk packages (18 pieces)**

Type	Stock number	Applications	Inputs	Outputs
DXR2.E12P-102A/BP (Version with 30 data points)	S55376-C163	Variable air volume, dual duct VAV, fan-powered box, radiant ceiling, radiator, 4 luminaires & 2 blinds	1 DI, 2 UI, ΔP sensor	6 Triacs, 2 AO
DXR2.E18-101A/BP	S55376-C162	Fan coil, dual duct VAV, radiant ceiling, radiator, 4 luminaires & 2 blinds	2 DI, 4 UI	8 Triacs, 4 AO
DXR2.E18-102A/BP	S55376-C167	Variable air volume, fan-powered box, radiant ceiling, radiator, 4 luminaires & 2 blinds	2 DI, 4 UI	8 Triacs, 4 AO

**Order numbers U.S. and Canada  
Individual packages only**

Type	Stock number	Applications	Inputs	Outputs
DXR2.E12P-102B (Version with 30 data points)	S55376-C126	Variable air volume, dual duct VAV, fan-powered box, radiant ceiling, radiator, 4 luminaires & 2 blinds	1 DI, 2 UI, ΔP sensor	6 Triacs, 2 AO
DXR2.E12PX-102B (Version with 60 data points)	S55374-C252	Variable air volume, dual duct VAV, fan-powered box, radiant ceiling, radiator, 4 luminaires & 2 blinds	1 DI, 2 UI, ΔP sensor	6 Triacs, 2 AO
DXR2.E18-101B	S55376-C125	Fan coil, dual duct VAV, heat pump, radiant ceiling, radiator, 4 luminaires & 2 blinds	2 DI, 4 UI	8 Triacs, 4 AO

**Accessories**

Type	Stock number	Designation
DXA.H180	S55376-C120	Terminal cover for DXR.. 180 mm, 2 pieces

**Product documentation**

Topic	Title	Document ID:
Engineering, mounting and installation	Desigo™ Room Automation	CM111043
Engineering and commissioning, workflow	ABT online help	n/a
Commissioning	Desigo Raumautomation - Setup and Service Assistant	CM111050
Product environmental declaration	Product environmental declaration 230 V	CM1E9204
Product environmental declaration	Product environmental declaration 24 V	CM1E9205

Related documents such as the environmental declarations, declarations of conformity, etc., can be downloaded from the following Internet address:

[www.siemens.com/bt/download](http://www.siemens.com/bt/download)

**⚠ CAUTION****National safety regulations**

Failure to comply with national safety regulations may result in personal injury and property damage.

- Observe national provisions and comply with the appropriate safety regulations.

**Engineering****Identification**

Each device has a unique serial number to ensure efficient commissioning. It is provided on the adhesive barcode label. The serial number can be read directly into the engineering tool using a barcode reader.

**Wiring**

Wiring must be sufficiently insulated to the available rated voltage. Sizing and fusing of the wiring depends on the connected load.

**Triac outputs AC 24 V**

Individual Triac outputs may have a max. load of 6 VA (heating up the device). The following possibilities are permitted:

- Multiple motorized actuators with a total of max. 6 VA.
- 1 thermal actuator with 6 VA start load in a cold state, controlled using the algorithm PWM 0...100%.
- 2 thermal actuators with 6 VA start load each in a cold state, controlled using the algorithm PWM 5...50%.

For transformer design (voltage drop off), each thermal actuator must be counted at the full start load, since the Triac outputs can be freely controlled.

The heating sequence and cooling sequence are not normally active at the same time (Exception: Downdraft compensation).

The sum total of the base load, bus power, field supply, and Triacs may not exceed 72 VA (DXR2.E..) or 70 VA (DXR2.M..). Power consumption is 96 VA with pulse width modulation. See Section **Power data**.

For the DXR2.. 24 V variant, the high side switch Triacs (closed the contact at AC 24 V) are used. As a result, the VAV compact controllers GDB181.1E/3 or GLB181.1E/3 can only be set to operating mode "con" via 0...10 V.

**DC 0...10 V outputs**

The DC 0...10 V outputs supply max. 1 mA.

**AC 24 V supply for field devices (V~)**

Actuators (valves, dampers) and active sensors are supplied directly by the device. Separate AC 24 V power supply is only required if field devices consume more than 12 VA (on DXR2.x11.. and DXR2.x12..) or 18 VA (on DXR2.x18).

**DC 24 V power supply for field devices (V+), DXR2.x18 only**



Actuators (valves, dampers) and active sensors are supplied directly by the device. A separate DC 24 V field supply is only required if field devices use more than 2.4 Watts.

**Digital inputs**

Digital inputs are not suitable for operating lighting or blinds. Use the KNX PL-Link pushbutton.

## Mounting

The room automation stations can be snapped onto standard rails or screwed onto a flat surface.

 <b>CAUTION</b>	
	<p><b>Risk of overheating for failure to comply with ambient temperature</b></p> <p>Burning and damage to the device</p> <ul style="list-style-type: none"><li>• Ensure sufficient ventilation to comply with the permissible ambient temperature within the panel or installation box. The temperature must be at least 10 K (18° F) lower outside the installation box.</li></ul>



### Mounting position

Ambient temperature -5...45 °C (23...113°F)	Ambient temperature -5...50 °C (23...122°F)
<ol style="list-style-type: none"><li>1. Overhead</li><li>2. Wall, vertically<ul style="list-style-type: none"><li>– From top to bottom</li><li>– From bottom to top</li></ul></li><li>3. On a horizontal surface</li></ol>	<ul style="list-style-type: none"><li>• Wall, horizontal<ul style="list-style-type: none"><li>– From left to right</li><li>– From right to left</li></ul></li></ul>

### Differential pressure sensor

- Avoid bends and pressure when attaching the tube.
- Connect the "+" connection on the side with the higher pressure and the "-" connection on the side with the lower pressure.
- A tube length of 2 m (6 ft) is recommended.

## Installation

 <b>WARNING</b>	
	<p>Risk of fire and injury due to short circuits!</p> <ul style="list-style-type: none"><li>• Adapt as per local regulations the wiring cross section to the rated value of the installed fuse.</li></ul>

### Strain relief

Strain relief protects flexible electrical wiring against mechanical stress.

The wiring must be fixed using cable binders to the tabs on the housing base.

### Terminal cover

Break off the cable inlets to insert the cables to the room automation station.

To take off the terminal cover:

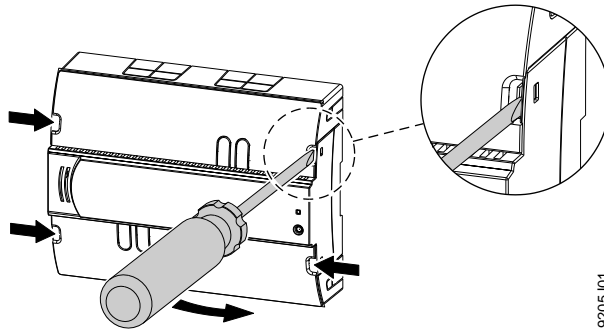

### Operation

The outputs have no electricity when power fails.

USB communications that does not work points to improper grounding of AC 24 V operating voltage (connection  $\perp$  must be grounded).

### Disposal



The device is considered an electronic device for disposal in accordance with European Directive and may not be disposed of as domestic waste.

- Use only designated channels for disposing the devices.
- Comply with all local and currently applicable laws and regulations.

### Warranty

Technical data on specific applications is only valid on Siemens products. Siemens rejects any and all warranties in the event that third-party products are used.



## Technical data

### Housing

Color	RAL 7035 (light-gray)
Dimensions	See Dimensions
Weight DXR2.E18.. DXR2.E12P.. Terminal cover Packaging	ca. 350 g ca. 330 g ca. 80 g ca. 40 g

### Function data

Processor	Texas Instruments AM3352, 300 MHz
RAM	128 MByte SDRAM (DDR3) 512 MByte NAND Flash
Communication A/D Resolution (analog in) D/A Resolution (analog out)	14 Bit 12 Bit

### Power data

Power supply	
Operating voltage	AC 24 V -15%/+20%
Frequency	50/60 Hz
Power consumption including connected field devices DXR2.E12P.. DXR2.E18..	Max. 60 VA Max. 72 VA
Internal fuse	4 A irreversible
Transformer with secondary current limitation of max. 10 A or external secondary current fuse Non-renewable fuse Circuit breakers	Max. 10 A, slow Max. 13 A, characteristic B, C, D as per EN 60898

Apparent power (VA) for transformer design						
	Base load including I/O without load by field devices	Max. output load Triac at 250 mA each	Max. load for AC 24 V field supply at 500/750 mA	Max. load KNX PL-Link at 50 mA	Max. load for DC 24 V field supply at 100 mA	Power consumption including connected field devices
DXR2.E12P..	8	6 x 6 = 36 (72 with PWM *)	12	4	-	60 (96 with PWM *)
DXR2.E18..	8	8 x 6 = 48 (88 with PWM *)	18	4	6	84 (96 with PWM *)

\*) For thermal valve actuators (starting current) with pulse width modulation 5...50% and pulse length of ca. 1 s.

Power for the Triac outputs must be reduced if the max. load of 18 VA is required for AC 24 V field supply on the DXR2.x18...

## Inputs

The inputs are protected against incorrect wiring AC 24 V.

Inputs: Overview	
Type	Inputs
DXR2.E12P..	1 DI, 2 UI, ΔP sensor
DXR2.E18..	2 DI, 4 UI

Resistance sensor, analog (inputs X...)		
Type	Range (over range)	Resolution
AI 1000 Ohm *)	1 kΩ (0...1.05 kΩ)	1 Ω
AI 2500 Ohm *)	2.5 kΩ (0...2.625 kΩ)	2.5 Ω
AI 10 kOhm *)	10 kΩ (0...10.5 kΩ)	10 Ω
AI 100 kOhm *)	100 kΩ (0...105 kΩ)	100 Ω

Temperature measurement, analog (inputs X...)		
Type	Range (over range)	Resolution
AI PT1K 375 (NA) *)	-40...70 °C (-45...75 °C) -40...158 °F (-49...167 °F)	25 mK 0.045 °F
AI PT1K 385 (EU) *)	-40...70 °C (-45...75 °C) -40...158 °F (-49...167 °F)	25 mK 0.045 °F
AI (LG-)Ni1000 *)	-40...70 °C (-45...75 °C) -40...158 °F (-49...167 °F)	25 mK 0.045 °F
AI Ni1000 DIN *)	-40...70 °C (-45...75 °C) -40...158 °F (-49...167 °F)	25 mK 0.045 °F
AI T1 (PTC) *)	-40...70 °C (-45...75 °C) -40...158 °F (-49...167 °F)	100 mK 0.18 °F
AI NTC10K (Typ II / Beta (0-50 °C) = 3892 K)	-40...70 °C (-45...75 °C) -40...158 °F (-49...167 °F)	25 mK (25 °C) 0.045 °F (77 °F)
AI NTC100K	-10...70 °C (-15...75 °C) 14...158 °F (5...167 °F)	25 mK (25 °C) 0.045 °F (77 °F)

\*) A fixed value of 1 Ω is calibrated to correct line resistance.

Voltage measurement, analog (inputs X...)		
Type	Range (over range)	Resolution
AI 0...10 V	0...10 V (-1...11 V)	2 mV
AI 0...10 V standard	0...100% (-10...110%)	2 mV
Open connection: Negative voltage -1.5 V, 8 μA (line failure detection)		

Digital input (inputs X... or D...)	
Contact query voltage	Universal input: 18 V Digital input: 21 V
Contact query current	Universal input: 1.2 mA, 7.4 mA initial current Digital input: 1.6 mA; 9.4 mA initial current
Contact resistance for closed contacts	Max. 100 Ω
Contact resistance for open contacts	Min. 50 kΩ

Differential pressure sensor (inputs P1+, P1-)	
Connections (nipple diameter)	5.2 mm
Measuring range	0...500 Pa
Overload range	0...100 kPa
Measuring range accuracy	4.5%
Zero point accuracy	0.2 Pa
Resolution	12 Bit

## Outputs

The outputs are protected against short circuiting and incorrect wiring AC 24 V.

Outputs: Overview	
Type	Outputs
DXR2.E12P..	6 Triacs, 2 AO
DXR2.E18..	8 Triacs, 4 AO

Analog (outputs Y10...Y40)			
Type	Range (over range)	Resolution	Output current
AO 0-10 V	0...10 V (0...10.5 V)	2 mV	Max. 1 mA
AO 0-10 V standard	0...100% 0% = 0 V, 100% = 10 V (0...10.5 V)	2 mV	Max. 1 mA

Switching outputs Triac (outputs Y1...Y8)	
Type	High side The Triac closes the contact to AC 24 V
Switching voltage	AC 24 V
Permissible load	250 mA / 6 VA per output (cos phi 0.35) (500 mA / 12 VA per output with PWM *)
Protection	Short-circuit proof

\*) For thermal valve actuators (starting current) with pulse width modulation 5...50% and pulse length of ca. 1 s.

Supply for field devices (outputs V~)	
Output voltage	AC 24 V
Permissible load DXR2.x11.. und DXR2.x12P.. DXR2.x18..	500 mA / 12 VA overall 750 mA / 18 VA overall
Protection against overload	Short-circuit proof

Power supply for field devices on DXR2.x18 (output V+)	
Output voltage	DC 24 V
Permissible load	100 mA/2.4 W
Protection against overload	Short-circuit proof

## Connections

Interfaces	
Ethernet	Plugs: 2 x RJ45, screened Interface type: 10Base-T/100BASE-TX, IEEE 802.3 compatible Bitrates: 10/100 Mbps, autosensing Protocol: <ul style="list-style-type: none"> <li>• BACnet/IP (Annex J)</li> <li>• BACnet/SC (Annex AB), as BACnet Secure Connect node</li> </ul>
USB (2.0)	Plug: Type B Data rate: 12 Mbps
KNX	Type: KNX TP1 PL-Link, galvanic isolation Baud rate: 9.6 kbps Bus power: 50 mA Short-circuit proof, and protected against faulty wiring at max. AC 24 V

Wiring connections	
Pluggable screw terminals	Copper wire or copper stranded wire with connector sleeves 1 x 0.6 mm $\varnothing$ to 2.5 mm <sup>2</sup> (22 to 14 AWG) or 2 x 0.6 mm $\varnothing$ to 1 mm <sup>2</sup> (22 to 18 AWG) Copper stranded wire without connector sleeves 1 x 0.6 mm $\varnothing$ to 2.5 mm <sup>2</sup> (22 to 14 AWG) or 2 x 0.6 mm $\varnothing$ to 1.5 mm <sup>2</sup> (22 to 16 AWG)
Stripping length	6...7.5 mm (0.24...0.29 in)
Slotted screws	Size 1, tightening torque 0.6 Nm (0.44 lb-ft)
Wiring lengths for signals	KNX PL-Link 80 m (260 ft) with internal bus power or 300 m (990 ft) with external power supply Ethernet 100 m (330 ft) Signal lines 80 m (260 ft) For inputs AI 100 kOhm, AI NTC10K, AI NTC100K: 30 m (100 ft) or 80 m (260 ft), if shielded.

Ambient conditions and protection classification	
Classification per IEC/EN 60730 Function of automatic control devices Pollution degree Overvoltage category	Type 1 2 I
Protection against electric shock	Protection class III
Degree of protection of housing to IEC EN 60529 Room automation station With terminal cover	IP20 IP30
Climatic ambient conditions <ul style="list-style-type: none"> <li>• Transport (packaged for transport) as per IEC EN 60721-3-2</li> <li>• Operation as per IEC/EN 60721-3-3</li> </ul>	<ul style="list-style-type: none"> <li>• Class 2K3 Temperature -25...70 °C (-13... 158 °F) Air humidity 5...95% (non-condensing)</li> <li>• Class 3K5 Temperature -5...45 °C (23... 113 °F)/ -5...50 °C (23... 122 °F) See Mounting Air humidity 5...95% (non-condensing)</li> </ul>
Mechanical ambient conditions Transport as per IEC/EN 60721-3-2 Operation as per IEC/EN 60721-3-3	Class 2M2 Class 3M2

Standards, directives and approvals	
Product standard	IEC/EN 60730-1 Automatic electronic controls for household and similar use
Product family standard	EN 50491-2, EN 50491-3, EN 50491-5 General requirements for Home and Building Electronic Systems (HBES) and Building Automation and Control Systems (BACS)
Electromagnetic compatibility	For residential, commercial, and industrial environments
EU conformity (CE)	EU declaration of conformance DXR2.. AC 230 V, see CM1T9204xx_1 EU declaration of conformance DXR2.. AC 24 V, see CM1T9204xx_2
RCM conformity	RCM declaration of conformance DXR2.. see CM1T9204xx_C1
EAC compliance	Eurasien compliance for all DXR2.xxx-xxxA variants
UL Approbation	UL as per UL916, <a href="http://ul.com/database">http://ul.com/database</a> cUL as per CSA – C22.2 No. 205
Federal Communications Commission	FCC CFR 47 Part 15 Class B
BACnet	BTL listed, BACnet Advanced Application Controller (B-AAC) BACnet Protocol Revision 15

Standards, directives and approvals	
eu.bac certification	DXR2.E.. room automation stations are eu.bac certified for different applications. Detailed information can be found on the CLMS website: <a href="http://www.eubaccert.org/licences-by-criteria.asp">http://www.eubaccert.org/licences-by-criteria.asp</a> .
Environmental compatibility	The product environmental declaration () contains data on environmentally compatible product design and assessments (RoHS compliance, materials composition, packaging, environmental benefit, disposal). See Section <b>Product documentation</b> .
Quality	ISO 9001 (Quality)

### European Union conformity

Contact for regulatory topics: (EU) Siemens AG, Berliner Ring 23, DE-76437 Rastatt

DXR2.E12P

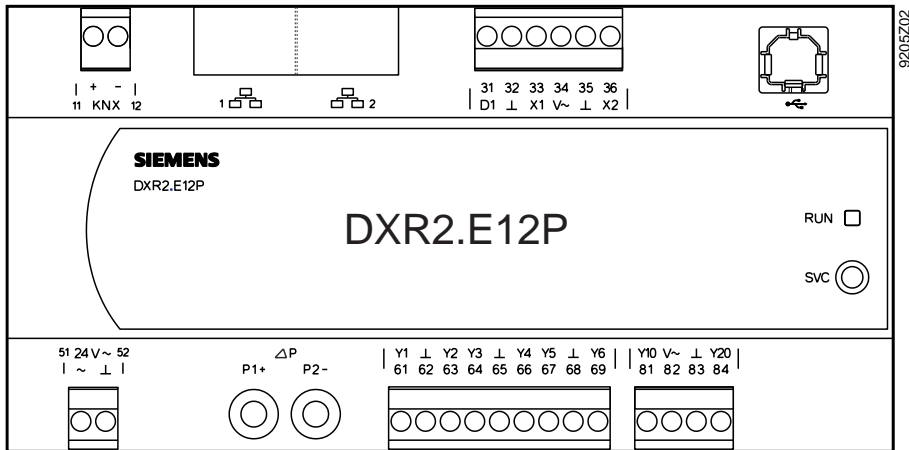

9205202

Terminal	Symbol	Description	Module	Channel
1, 2 Ethernet		2 x RJ45 interface for 2-port Ethernet switch		
11, 12 KNX	+, -	KNX connection		
31...36 inputs	D1	Digital input	1	1
	X1, X2	Universal input	1	5, 6
	⊥	System zero		
	V~	Field supply AC 24 V for active sensors		
USB		USB interface		
51...52 power 24 V~	V~	Power SELV / PELV AC 24 V		
	⊥	System zero		
61...69 Triacs	Y1...Y6	Switching output AC 24 V	11	1...6
	⊥	System zero		
81...84 analog outputs	Y10, Y20	Positioning output DC 0...10 V	21	1, 2
	⊥	System zero		
	V~	Field supply AC 24 V		
ΔP differential pressure detector	P1+	Connected to the higher pressure	31	1
	P1-	Connected to the lower pressure	31	1
Service	SVC	Service button		
Display	RUN	Operation LED		

**DXR2.E18**

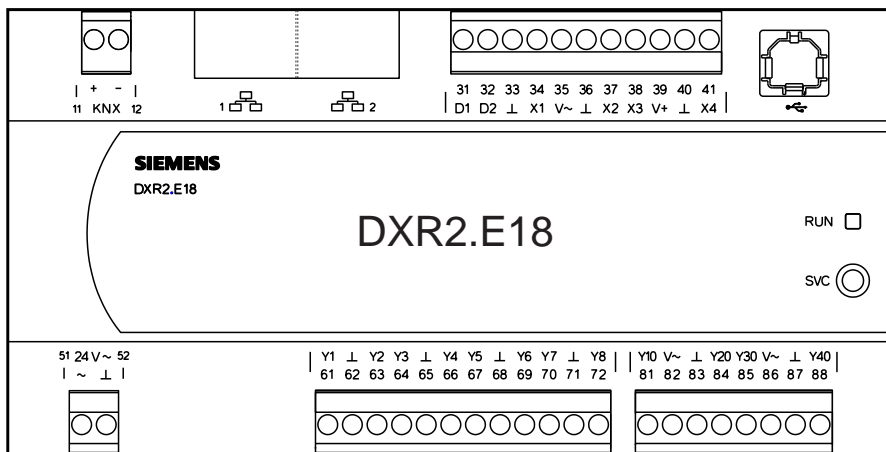

Terminal	Symbol	Description	Module	Channel
1, 2 Ethernet		2 x RJ45 interface for 2-port Ethernet switch		
11, 12 KNX	+, -	KNX connection		
31...41 inputs	D1, D2	Digital input	1	1, 2
	X1...X4	Universal input	1	5...8
	⊥	System zero		
	V~	Field supply AC 24 V for active sensors		
	V+	Field supply DC 24 V for active sensors		
USB		USB interface		
51...52 power 24 V~	V~	Power SELV / PELV AC 24 V		
	⊥	System zero		
61...72 Triacs	Y1...Y8	Switching output AC 24 V	11	1...8
	⊥	System zero		
81...88 analog outputs	Y10...Y40	Positioning output DC 0...10 V	21	1...4
	⊥	System zero		
	V~	Field supply AC 24 V		
Service	SVC	Service button		
Display	RUN	Operation LED		



Without terminal cover

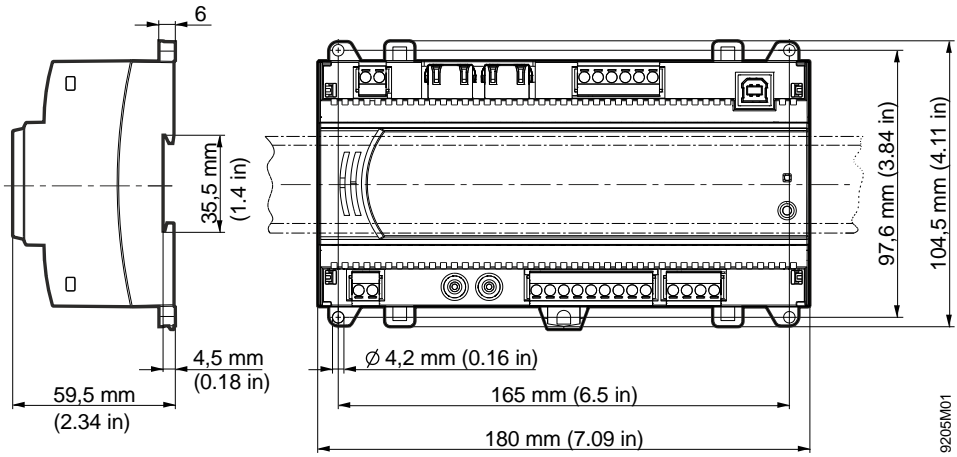

With terminal cover

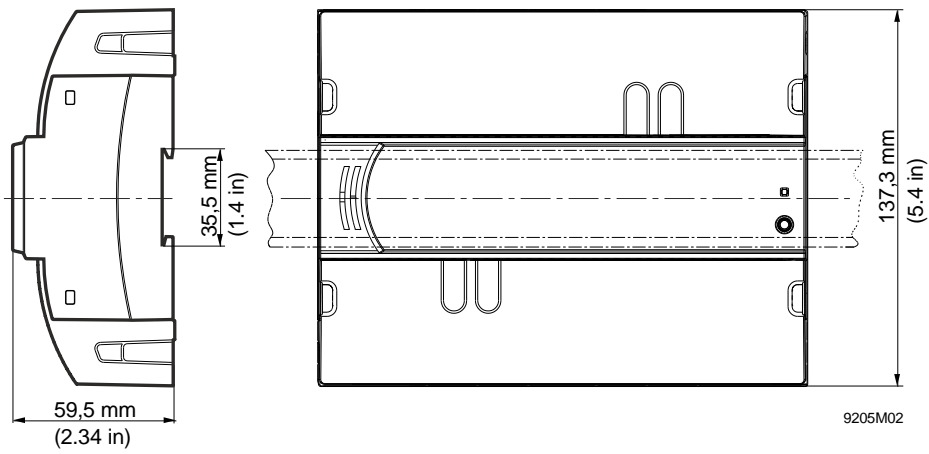

Issued by  
Siemens Switzerland Ltd  
Smart Infrastructure  
Global Headquarters  
Theilerstrasse 1a  
CH-6300 Zug  
+41 58 724 2424  
[www.siemens.com/buildingtechnologies](http://www.siemens.com/buildingtechnologies)

© Siemens 2013  
Technical specifications and availability subject to change without notice.

---

Document ID    CM1N9205en  
Edition        2023-07-04