

SIEMENS

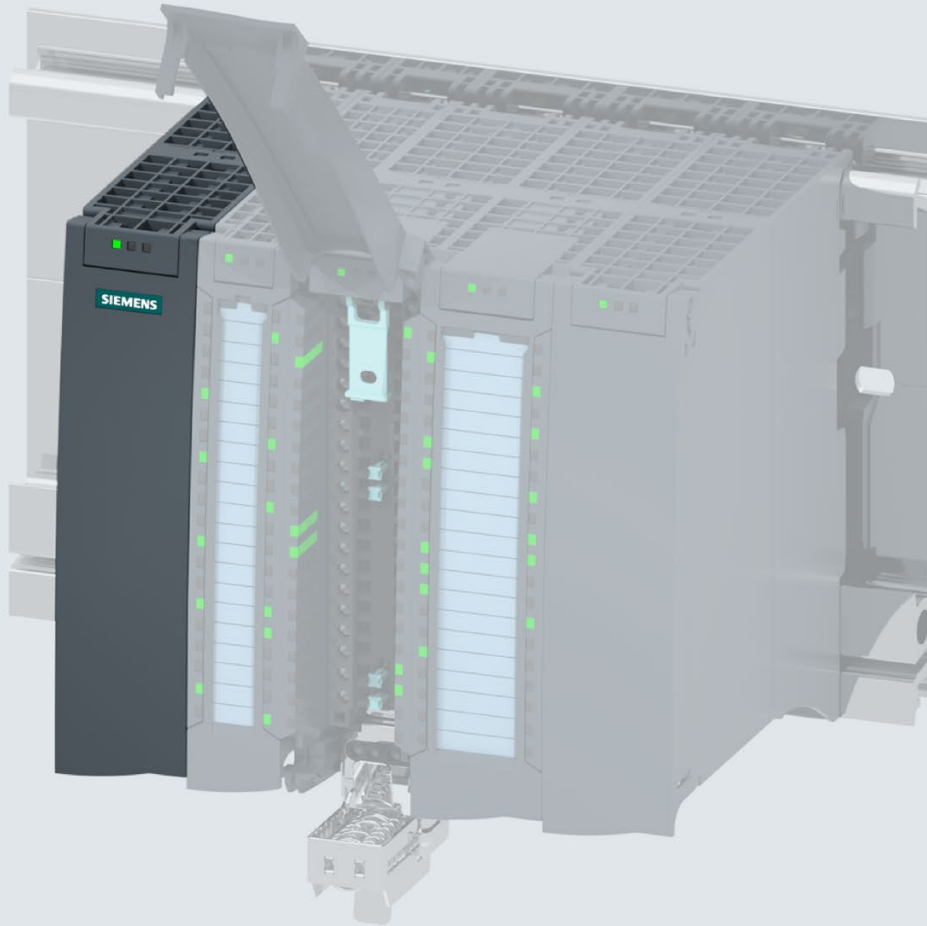

Manual

SIMATIC

ET 200MP

Interface module IM 155-5 PN HF
(6ES7155-5AA00-0AC0)

Edition

10/2018

support.industry.siemens.com

SIEMENS

SIMATIC

ET 200MP IM 155-5 PN HF Interface Module (6ES7155-5AA00-0AC0)

Manual

Preface

Guide to documentation

1

Product overview

2

Wiring

3

Parameter

4

Interrupts and diagnostic,
error, and system alarms

5

Technical specifications

6

Dimension drawing

A



Response times

B

Legal information

Warning notice system

This manual contains notices you have to observe in order to ensure your personal safety, as well as to prevent damage to property. The notices referring to your personal safety are highlighted in the manual by a safety alert symbol, notices referring only to property damage have no safety alert symbol. These notices shown below are graded according to the degree of danger.

 DANGER
indicates that death or severe personal injury will result if proper precautions are not taken.
 WARNING
indicates that death or severe personal injury may result if proper precautions are not taken.
 CAUTION
indicates that minor personal injury can result if proper precautions are not taken.
NOTICE
indicates that property damage can result if proper precautions are not taken.

If more than one degree of danger is present, the warning notice representing the highest degree of danger will be used. A notice warning of injury to persons with a safety alert symbol may also include a warning relating to property damage.

Qualified Personnel

The product/system described in this documentation may be operated only by **personnel qualified** for the specific task in accordance with the relevant documentation, in particular its warning notices and safety instructions. Qualified personnel are those who, based on their training and experience, are capable of identifying risks and avoiding potential hazards when working with these products/systems.

Proper use of Siemens products

Note the following:

 WARNING
Siemens products may only be used for the applications described in the catalog and in the relevant technical documentation. If products and components from other manufacturers are used, these must be recommended or approved by Siemens. Proper transport, storage, installation, assembly, commissioning, operation and maintenance are required to ensure that the products operate safely and without any problems. The permissible ambient conditions must be complied with. The information in the relevant documentation must be observed.

Trademarks

All names identified by ® are registered trademarks of Siemens AG. The remaining trademarks in this publication may be trademarks whose use by third parties for their own purposes could violate the rights of the owner.

Disclaimer of Liability

We have reviewed the contents of this publication to ensure consistency with the hardware and software described. Since variance cannot be precluded entirely, we cannot guarantee full consistency. However, the information in this publication is reviewed regularly and any necessary corrections are included in subsequent editions.

Preface

Purpose of the documentation

This manual supplements the system manual S7-1500, ET 200MP Automation system (<https://support.industry.siemens.com/cs/ww/en/view/59191792>). Functions that generally relate to the system are described in this manual.

The information provided in this manual and in the system/function manuals supports you in commissioning the system.

Conventions

Please also observe notes labeled as follows:

Note

A note contains important information on the product described in the documentation, on the handling of the product, or on the section of the documentation to which particular attention should be paid.

Recycling and disposal

For environmentally friendly recycling and disposal of your old equipment, contact a certified electronic waste disposal company and dispose of the equipment according to the applicable regulations in your country.

Security information

Siemens provides products and solutions with industrial security functions that support the secure operation of plants, systems, machines and networks.

In order to protect plants, systems, machines and networks against cyber threats, it is necessary to implement – and continuously maintain – a holistic, state-of-the-art industrial security concept. Siemens' products and solutions constitute one element of such a concept.

Customers are responsible for preventing unauthorized access to their plants, systems, machines and networks. Such systems, machines and components should only be connected to an enterprise network or the internet if and to the extent such a connection is necessary and only when appropriate security measures (e.g. firewalls and/or network segmentation) are in place.

For additional information on industrial security measures that may be implemented, please visit (<https://www.siemens.com/industrialsecurity>).

Siemens' products and solutions undergo continuous development to make them more secure. Siemens strongly recommends that product updates are applied as soon as they are available and that the latest product versions are used. Use of product versions that are no longer supported, and failure to apply the latest updates may increase customers' exposure to cyber threats.

To stay informed about product updates, subscribe to the Siemens Industrial Security RSS Feed under (<https://www.siemens.com/industrialsecurity>).

Table of contents

	Preface	3
1	Guide to documentation	7
2	Product overview	12
2.1	Properties	12
2.2	Functions	14
2.2.1	PROFINET IO	14
2.2.2	Configuration control (option handling)	20
2.2.3	System redundancy on S7-400H	20
3	Wiring	21
3.1	Pin assignment	21
3.2	Block diagram	22
4	Parameter	23
4.1	Parameters	23
4.2	Description of parameters	23
4.2.1	Connection to supply voltage L+	23
4.2.2	Configuration control (option handling)	24
4.3	Configuration control (option handling)	25
4.3.1	Configuration control and control data record	25
4.3.2	Feedback data record	29
4.3.3	Configure configuration control without empty slots	30
4.3.4	Extending the configuration	32
4.3.5	Combining configurations	34
5	Interrupts and diagnostic, error, and system alarms	36
5.1	Status and error displays	36
5.2	Interrupts	38
5.2.1	Triggering of a diagnostic interrupt	39
5.2.2	Triggering of a hardware interrupt	40
5.3	Alarms	41
5.3.1	Diagnostic alarms	41
5.3.2	Maintenance events	42
5.3.3	Channel diagnostics	43
5.3.4	Invalid configuration states of the ET 200MP on PROFINET IO	47
5.3.5	STOP of the IO controller and recovery of the IO device	48
6	Technical specifications	49
A	Dimension drawing	53
B	Response times	55
B.1	Response times of the ET 200MP	55

Guide to documentation

The documentation for the SIMATIC S7-1500 automation system and the SIMATIC ET 200MP distributed I/O system is arranged into three areas. This arrangement enables you to access the specific content you require.

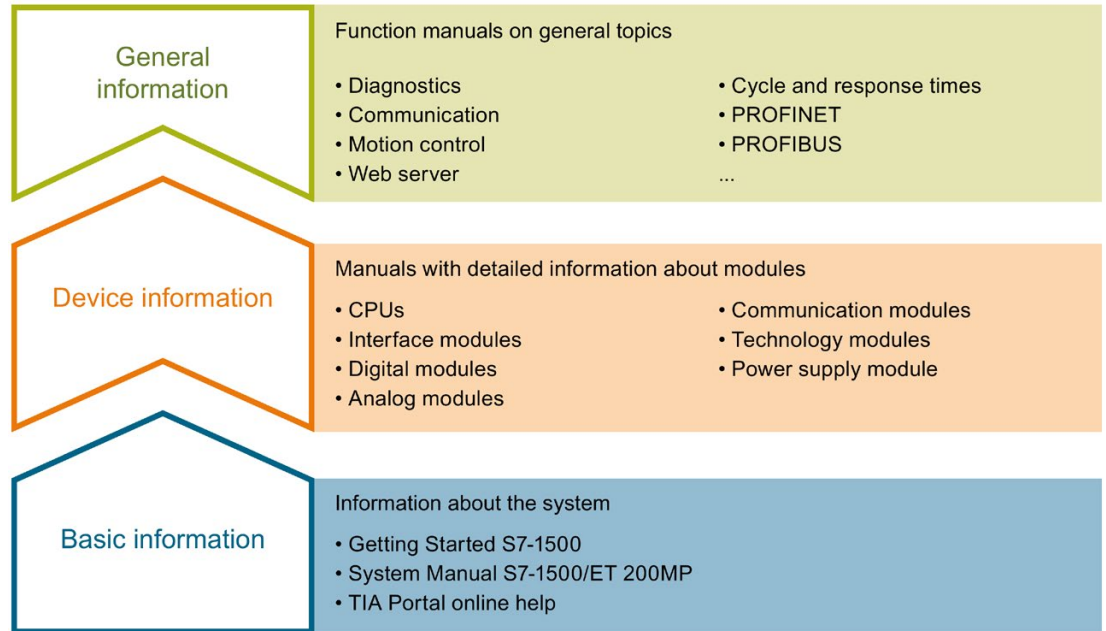

Basic information

The System Manual and Getting Started describe in detail the configuration, installation, wiring and commissioning of the SIMATIC S7-1500 and ET 200MP systems. The STEP 7 online help supports you in the configuration and programming.

Device information

Product manuals contain a compact description of the module-specific information, such as properties, wiring diagrams, characteristics and technical specifications.

General information

The function manuals contain detailed descriptions on general topics regarding the SIMATIC S7-1500 and ET 200MP systems, e.g. diagnostics, communication, motion control, Web server, OPC UA.

You can download the documentation free of charge from the Internet (<https://support.industry.siemens.com/cs/ww/en/view/109742691>).

Changes and supplements to the manuals are documented in a Product Information.

You can download the product information free of charge from the Internet (<https://support.industry.siemens.com/cs/us/en/view/68052815>).

Manual Collection S7-1500/ET 200MP

The Manual Collection contains the complete documentation on the SIMATIC S7-1500 automation system and the ET 200MP distributed I/O system gathered together in one file.

You can find the Manual Collection on the Internet (<https://support.industry.siemens.com/cs/ww/en/view/86140384>).

SIMATIC S7-1500 comparison list for programming languages

The comparison list contains an overview of which instructions and functions you can use for which controller families.

You can find the comparison list on the Internet (<https://support.industry.siemens.com/cs/ww/en/view/86630375>).

"mySupport"

With "mySupport", your personal workspace, you make the best out of your Industry Online Support.

In "mySupport", you can save filters, favorites and tags, request CAx data and compile your personal library in the Documentation area. In addition, your data is already filled out in support requests and you can get an overview of your current requests at any time.

You must register once to use the full functionality of "mySupport".

You can find "mySupport" on the Internet (<https://support.industry.siemens.com/My/ww/en>).

"mySupport" - Documentation

In the Documentation area in "mySupport" you can combine entire manuals or only parts of these to your own manual.

You can export the manual as PDF file or in a format that can be edited later.

You can find "mySupport" - Documentation on the Internet (<http://support.industry.siemens.com/My/ww/en/documentation>).

"mySupport" - CAx data

In the CAx data area in "mySupport", you can access the current product data for your CAx or CAe system.

You configure your own download package with a few clicks.

In doing so you can select:

- Product images, 2D dimension drawings, 3D models, internal circuit diagrams, EPLAN macro files
- Manuals, characteristics, operating manuals, certificates
- Product master data

You can find "mySupport" - CAx data on the Internet (<http://support.industry.siemens.com/my/ww/en/CAxOnline>).

Application examples

The application examples support you with various tools and examples for solving your automation tasks. Solutions are shown in interplay with multiple components in the system - separated from the focus on individual products.

You will find the application examples on the Internet (<https://support.industry.siemens.com/sc/ww/en/sc/2054>).

TIA Selection Tool

With the TIA Selection Tool, you can select, configure and order devices for Totally Integrated Automation (TIA).

This tool is the successor of the SIMATIC Selection Tool and combines the known configurators for automation technology into one tool.

With the TIA Selection Tool, you can generate a complete order list from your product selection or product configuration.

You can find the TIA Selection Tool on the Internet (<http://w3.siemens.com/mcms/topics/en/simatic/tia-selection-tool>).

SIMATIC Automation Tool

You can use the SIMATIC Automation Tool to perform commissioning and maintenance activities simultaneously on various SIMATIC S7 stations as a bulk operation independent of the TIA Portal.

General function overview:

- Network browsing and creation of a table showing the accessible devices in the network.
- Flashing of device LEDs or HMI display to locate a device
- Downloading of addresses (IP, subnet, gateway) to a device
- Downloading the PROFINET name (station name) to a device
- Placing a CPU in RUN or STOP mode
- Setting the time in a CPU to the current time of your PG/PC
- Downloading a new program to a CPU or an HMI device
- Downloading from CPU, downloading to CPU or deleting recipe data from a CPU
- Downloading from CPU or deleting data log data from a CPU
- Backup/restore of data from/to a backup file for CPUs and HMI devices
- Downloading service data from a CPU
- Reading the diagnostics buffer of a CPU
- Performing a CPU memory reset
- Resetting devices to factory settings
- Downloading a firmware update to a device

You can find the SIMATIC Automation Tool on the Internet (<https://support.industry.siemens.com/cs/ww/en/view/98161300>).

PRONETA

With SIEMENS PRONETA (PROFINET network analysis), you analyze the PROFINET network during commissioning. PRONETA features two core functions:

- The topology overview independently scans PROFINET network and all connected components.
- The IO check is a fast test of the wiring and the module configuration of a system.

You can find SIEMENS PRONETA on the Internet (<https://support.industry.siemens.com/cs/ww/en/view/67460624>).

SINETPLAN

SINETPLAN, the Siemens Network Planner, supports you in planning automation systems and networks based on PROFINET. The tool facilitates professional and predictive dimensioning of your PROFINET installation as early as in the planning stage. In addition, SINETPLAN supports you during network optimization and helps you to exploit network resources optimally and to plan reserves. This helps to prevent problems in commissioning or failures during productive operation even in advance of a planned operation. This increases the availability of the production plant and helps improve operational safety.

The advantages at a glance

- Network optimization thanks to port-specific calculation of the network load
- Increased production availability thanks to online scan and verification of existing systems
- Transparency before commissioning through importing and simulation of existing STEP 7 projects
- Efficiency through securing existing investments in the long term and optimal exploitation of resources

You can find SINETPLAN on the Internet (<https://www.siemens.com/sinetplan>).

Product overview

2.1 Properties

Order number

6ES7155-5AA00-0AC0

View of the module



Figure 2-1 View of the IM 155-5 PN HF interface module

Properties

- Technical properties
 - Connects the ET 200MP distributed I/O system with PROFINET IO
 - 24 VDC supply voltage (SELV/PELV)
 - PROFINET IO connection using RJ45 bus connector
- Supported functions (Page 14)

Maximum configuration

- 512 bytes I/O data per station
- The integrated power supply of the interface module feeds 14 W into the backplane bus. Up to 12 I/O modules can be supplied with this. The exact number of operable modules is determined by the power budget (see relevant section in the system manual S7-1500, ET 200MP Automation system (<https://support.industry.siemens.com/cs/ww/en/view/59191792>)).
- A maximum of one power supply module (PS) upstream from the interface module and two downstream from the interface module is possible.
- If you use a power supply module (PS) upstream from the interface module, the maximum possible configuration is a total of 32 modules (up to 30 modules downstream from the interface module).

2.2 Functions

2.2.1 PROFINET IO

Introduction

The interface module supports the following PROFINET IO functions:

- Integrated switch with 2 ports
- Supported Ethernet services: ping, arp, SNMP, LLDP
- Port diagnostics
- Deactivating ports
- Isochronous real-time communication (IRT)
- Minimum update time 250 μ s
- Prioritized startup
- Device replacement without PG
- Media redundancy (MRP)
- Media redundancy with planned duplication (MRPD)
- Shared Device with up to four IO controllers
- Module-internal Shared Input/Shared Output (MSI/MSO)
- Isochronous mode of process data
- Identification data I&M 0 to 3
- Firmware update via PROFINET IO
- Reset to factory settings via PROFINET IO
- Configuration control (option handling)
- System redundancy on S7-400H
- System redundancy S2
- IO devices changing during operation ("alternative partners")
 - Docking station

Requirements

The table below shows the software requirements for a configuration with the IM 155-5 PN HF interface module:

Table 2- 1 Requirements

PROFINET IO function	Configuration software		
	with GSD file ¹⁾		STEP 7 (TIA Portal) V13 or higher
	STEP 7 V5.5 SP3 or higher	STEP 7 (TIA Portal) V13 or higher	
Real-time communication	X	X	X
Isochronous real-time communication (IRT)	X	X	X
Prioritized startup	X	X	X
Device replacement without PG	X	X	X
Media redundancy (MRP)	X	X	X
Media redundancy with planned duplication (MRPD)	X	X	-
Shared Device			
• with up to two IO controllers	X	X ²⁾	-
• with up to four IO controllers	-	X ²⁾	-
Isochronous mode	-	-	X
System redundancy on S7-400H	X	-	-
System redundancy S2	X	-	As of V15.1
IO devices changing during operation ("alternative partners")	As of V5.6	As of V15.1	As of V15.1
• Docking station			

1) The usability of the PROFINET IO functions depends on the configuration software (Siemens and/or third party). Below, the usability of the PROFINET IO functions is described for STEP 7 only.

2) No validity check of Shared Device projects

Isochronous real-time communication

Synchronized transmission method for cyclic exchange of IRT data between PROFINET devices. A reserved bandwidth is available in the send cycle for IRT data. The reserved bandwidth ensures that IRT data can be transferred at reserved synchronized intervals, without being influenced by other network loads (e.g., TCP/IP communication, or additional real-time communication).

A topological configuration is required for IRT.

Note

IO controller as sync master with IRT communication

We recommend operating the IO controller as sync master when configuring IRT communication.

Otherwise, IO devices with IRT and RT configuration could fail as a result of sync master failure.

You can find additional information on configuration of synchronized PROFINET devices in sync domains in the STEP 7 online help and

- As of STEP 7 V12, in the PROFINET with STEP 7 (<http://support.automation.siemens.com/WW/view/en/49948856>) function manual
- As of STEP 7 V5.5, in the PROFINET System Description (<http://support.automation.siemens.com/WW/view/en/19292127>) manual

Prioritized startup

Prioritized startup denotes the PROFINET functionality for accelerating the startup of IO devices operated in a PROFINET IO system with RT communication.

The function reduces the time that the correspondingly configured IO devices require to return to the cyclic user data exchange in the following cases:

- After the supply voltage has returned
 - After a station has returned
 - After activation of IO devices
-

Note

Dependency of the startup time

The startup time depends on the number and type of modules. You can optimize the startup time by

- Inserting no more than 12 I/O modules
 - Inserting no power supply module.
-

The prioritized startup function with the requirements listed in the note above is not available for IRT communication and media redundancy.

You can find additional information in the STEP 7 online help and

- As of STEP 7 V12, in the PROFINET with STEP 7 (<http://support.automation.siemens.com/WW/view/en/49948856>) function manual
- As of STEP 7 V5.5, in the PROFINET System Description (<http://support.automation.siemens.com/WW/view/en/19292127>) manual

Cabling with fixed connection setting

If you set a fixed connection setting of the port in STEP 7, you should also deactivate "Autonegotiation/Autocrossover".

You can find additional information in the STEP 7 online help and

- As of STEP 7 V12, in the PROFINET with STEP 7 (<http://support.automation.siemens.com/WW/view/en/49948856>) function manual
- As of STEP 7 V5.5, in the PROFINET System Description (<http://support.automation.siemens.com/WW/view/en/19292127>) manual

Device replacement without PG

It is easy to replace IO devices that support this function:

- The device name does not have to be assigned with the PG.

The replaced IO device is assigned the device name by the IO controller. The IO controller uses the configured topology and the neighbor relationships determined by the IO devices for this purpose. All involved devices must support the LLDP protocol (Link Layer Discovery Protocol). The configured preset topology must match the actual topology.

IO devices that have been used in another configuration must be reset to the factory settings before they can be used again (see system manual S7-1500, ET 200MP Automation system (<https://support.industry.siemens.com/cs/ww/en/view/59191792>)).

You can find additional information in the STEP 7 online help and

- As of STEP 7 V12, in the PROFINET with STEP 7 (<http://support.automation.siemens.com/WW/view/en/49948856>) function manual
- As of STEP 7 V5.5, in the PROFINET System Description (<http://support.automation.siemens.com/WW/view/en/19292127>) manual

Media redundancy (MRP)

Function for safeguarding communication and plant availability. A ring topology ensures that an alternative communication path is made available if a transmission route fails.

You can find additional information in the STEP 7 online help and

- As of STEP 7 V12, in the PROFINET with STEP 7 (<http://support.automation.siemens.com/WW/view/en/49948856>) function manual
- As of STEP 7 V5.5, in the PROFINET System Description (<http://support.automation.siemens.com/WW/view/en/19292127>) manual

Media redundancy with planned duplication (MRPD)

If media redundancy is to be achieved in the case of short update times (together with IRT), you must use the MRP extension "Media redundancy with planned duplication (MRPD)".

You can find additional information in the STEP 7 online help and

- As of STEP 7 V12, in the PROFINET with STEP 7 (<http://support.automation.siemens.com/WW/view/en/49948856>) function manual
- As of STEP 7 V5.5, in the PROFINET System Description (<http://support.automation.siemens.com/WW/view/en/19292127>) manual

Shared Device

IO device that makes its data available to up to four IO controllers.

The interface module supports Shared Device operation at the submodule level. A prerequisite for using this function is that the I/O modules also support this.

Please note the following if **the Engineering System does not perform a validity check of the Shared Device projects**:

- Make sure that the configurations are consistent. In particular, the modules or submodules may only be assigned to one controller. Multiple assignment will result in an error; the module will only be available in the first controller.
- If you reconfigure Shared Device configurations without the validity check mentioned above, you have to commission the ET 200MP once again. This means that you have to reload the projects of all involved IO controllers to the specific CPU after reconfiguration and, if necessary, switch the interface module POWER OFF/POWER ON.

You can find additional information in the STEP 7 online help and

- As of STEP 7 V12, in the PROFINET with STEP 7 (<http://support.automation.siemens.com/WW/view/en/49948856>) function manual
- As of STEP 7 V5.5, in the PROFINET System Description (<http://support.automation.siemens.com/WW/view/en/19292127>) manual

Module-internal Shared Input/Shared Output (MSI/MSO)

The module-internal Shared Input function allows an input module to make its input data available to up to four IO controllers. Each controller has read access to the same channels.

The module-internal Shared Output function allows an output module to make its output data available to up to four IO controllers. One IO controller has write access. Up to three additional IO controllers can have read access to the same channels.

The combination of isochronous mode and Shared Device is not supported.

You can find additional information in the STEP 7 online help and

- As of STEP 7 V12, in the PROFINET with STEP 7 (<http://support.automation.siemens.com/WW/view/en/49948856>) function manual

Isochronous mode of process data

The process data, transmission cycles via PROFINET IO, and the user program are synchronized to achieve maximum deterministics. The input data and output data of distributed I/O devices in the plant are detected and output simultaneously. The isochronous PROFINET IO cycle forms the clock generator for this.

You can find additional information in the STEP 7 online help and

- As of STEP 7 V12, in the PROFINET with STEP 7 (<http://support.automation.siemens.com/WW/view/en/49948856>) function manual

System redundancy S2

An IO device with S2 system redundancy supports redundant ARs.

In a redundant system, an IO device with system redundancy S2 has a redundant AR for each of the two CPUs (IO controllers). If one CPU fails, the IO device with S2 system redundancy remains accessible to the remaining IO controller via the AR.

The interface module supports system redundancy S2 on S7-400H CPUs and on S7-1500R/H CPUs.

You can find additional information in the STEP 7 online help and

- As of STEP 7 V12, in the PROFINET with STEP 7 (<http://support.automation.siemens.com/WW/view/en/49948856>) function manual

IO devices changing during operation ("alternative partners") - docking station

You can use the PROFINET functionality "IO devices changing during operation" ("alternative partners"), e.g. for tool change for robots. Typical tools include:

- Welding guns
- Positioning tools for manufacturing parts

You can find additional information in the STEP 7 online help and

- As of STEP 7 V12, in the PROFINET with STEP 7 (<http://support.automation.siemens.com/WW/view/en/49948856>) function manual

2.2.2 Configuration control (option handling)

Properties

Configuration control allows you to prepare your distributed I/O system for future extensions or changes. Configuration control means that you can configure the planned maximum configuration of your distributed I/O system in advance and vary it later in a flexible manner by means of the user program.

Reference

You can find more information

- In chapter Configuration control (option handling) (Page 25)
- On the Internet (<http://support.automation.siemens.com/WW/view/en/29430270>)
- In the STEP 7 online help.

2.2.3 System redundancy on S7-400H

Interface to H-CPU with system redundancy

When system redundancy is used, you can connect the IM 155-5 PN HF (6ES7155-5AA00-0AC0) interface module to CPUs 41x-5H PN/DP (version 6.0 or higher) of the S7-400.

These CPUs allow you to operate the interface module as a component of a redundant system.

Requirements for the IM 155-5 PN HF interface module:

- With STEP 7 V5.5 SP3 and higher, the IM 155-5 PN HF is configured as a system redundancy device.
- The connection setting (transmission medium/duplex) must be set to "Full duplex".

Examples of system redundancy can be found in the manual Fault-tolerant systems S7-400H (<http://support.automation.siemens.com/WW/view/en/60458386>).

Combination of system redundancy and Shared Device

The IM 155-5 PN HF interface module can be connected to up to four IO controllers but only to one H-CPU pair. As a result, a combination of system redundancy and Shared Device operation is not possible when redundancy operation is used exclusively.

However, you can operate some of the I/O modules of the interface module in system redundancy on the H-CPU pair and the other I/O modules with up to two additional IO controllers in Shared Device operation.

Wiring

3.1 Pin assignment

24 VDC supply voltage

Table 3- 1 Pin assignment 24 VDC supply voltage

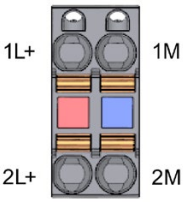
View	Signal name ¹⁾	Designation
	1L+	24 VDC
	2L+	24 VDC (for looping through) ²⁾
	1M	Ground
	2M	Ground (for looping through) ²⁾

1) 1L+ and 2L+, as well as 1M and 2M are bridged internally.

2) Maximum 10 A permitted

PROFINET IO with RJ45

Table 3- 2 PROFINET IO pin assignment with RJ45

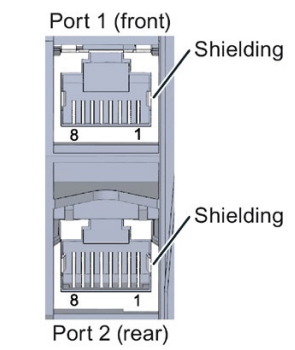
Bottom view IM	Signal name	Designation	
	1	TD	Transmit data +
	2	TD_N	Transmit data -
	3	RD	Receive data +
	4	GND	Ground
	5	GND	Ground
	6	RD_N	Receive data -
	7	GND	Ground
	8	GND	Ground

Additional information

You can find additional information on connecting the interface module and on accessories (RJ45 bus connector) in the system manual S7-1500, ET 200MP Automation system (<https://support.industry.siemens.com/cs/ww/en/view/59191792>).

3.2 Block diagram

Block diagram

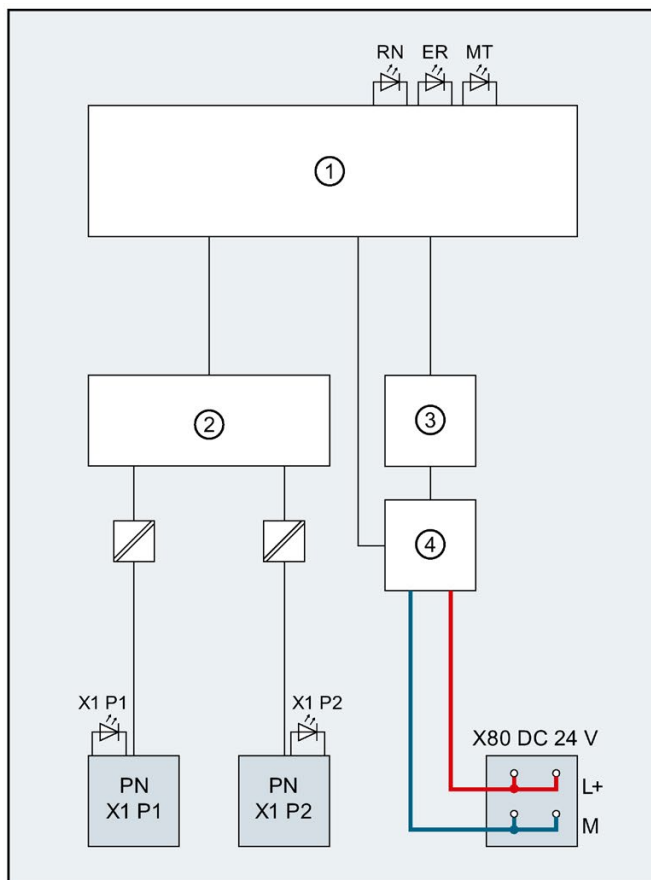

①	Electronics	L+	24 V DC supply voltage
②	PROFINET 2-port switch	M	Ground
③	Backplane bus interface	RN	RUN LED (green)
④	Internal supply voltage	ER	ERROR LED (red)
X80 24 V DC	Infeed of supply voltage	MT	MAINT LED (yellow)
PN X1 P1	PROFINET interface X1 port 1	X1 P1, X1 P2	Link TX/RX LED (green/yellow)
PN X1 P2	PROFINET interface X1 port 2		

Figure 3-1 Block diagram of the IM 155-5 PN HF interface module

Parameter

4.1 Parameters

Table 4- 1 Parameters for IM 155-5 PN HF interface module

Parameters	Value range	Default setting	Efficiency range
Connection to supply voltage L+	Connection/No connection	Connection	ET 200MP
Configuration control	Disable/enable	Disable	ET 200MP

4.2 Description of parameters

4.2.1 Connection to supply voltage L+

Parameter "Connection to supply voltage L+"

This parameter is used

- For diagnostics of the ET 200MP:
 - If the actual configuration is different from the preset configuration of the interface module supply voltage set with this parameter, the ET 200MP generates a diagnostic alarm.
- To check the power budget for the configuration with STEP 7 V13:
 - Depending on how the parameter is set, either the infeed power for the interface module into the backplane bus or the power consumption from the backplane bus is entered into the calculation of the power budget.

The default setting "Connection to supply voltage L+ " means that the front of the interface module is supplied with 24 VDC and feeds power into the backplane bus.

Note

We recommend that you always supply the front of the interface module with 24 VDC because if you then insert a power supply module (PS) **upstream** of the interface module, both the power of the power supply module (PS) and the power of the integrated power supply of the interface module are available for the I/O modules (power addition of PS infeed power + IM infeed power in power segment 1).

In this case, you do not have to change the default setting of the parameter in STEP 7.

4.2 Description of parameters

The setting "No connection to supply voltage L+" means that the interface module is not supplied with 24 VDC on the front. This can only be the case when a power supply module (PS) is inserted upstream from the interface module and supplies the interface module and the downstream modules. In the case of an interface module without power supply, its power consumption from the backplane bus must be considered as consumer in the power budget and the power segments must be formed accordingly.

Reference

See the section on the power budget and the forming of power segments in the system manual S7-1500, ET 200MP Automation system (<https://support.industry.siemens.com/cs/ww/en/view/59191792>).

Requirement

In order to generate diagnostics, the IM 155-5 PN HF interface module parameters must have been assigned once.

See also

Diagnostic alarms (Page 41)

4.2.2 Configuration control (option handling)

"Configuration control" parameter

You can use this parameter to enable the configuration control function in the ET 200MP Distributed I/O System.

Note

If you configure the enable, the ET 200MP distributed I/O system requires a control data record 196 from the user program in order for the ET 200MP distributed I/O system to operate the I/O modules.

Reference

You can find more information on the control data record in chapter Configuration control (option handling) (Page 25) and in the STEP 7 online help.

4.3 Configuration control (option handling)

4.3.1 Configuration control and control data record

Operating principle

You can use the configuration control to operate different real configurations (options) with a single configuration of the ET 200MP distributed I/O system. This is made possible by a configurable assignment of configured station modules to actually existing ones.

We distinguish between the following procedures:

- Configuring configuration control without empty slots (option handling)
- Expanding configuration (step-by-step commissioning)

Requirements

Enable the "Configuration control" parameter during configuration for this function. Control takes place with control data record 196 to specify the required configuration.

Configuration control is not ready for operation without control data record:

- All I/O modules of the ET 200MP distributed I/O system fail (substitute value behavior, if configured).
- The interface module continues to exchange data.

Rules: Arrangement of the modules

The following table shows the slot number assignment:

Table 4- 2 Assignment of slot numbers

Slot	Modules	Note
0	Power supply module (optional)	Before the interface module
1	Interface module	Interface module (slot 1) is not an element of the configuration control, but rather controls this
2 - 31	I/O modules / max. 2 power supply modules, depending on the configuration variant	After the interface module

4.3 Configuration control (option handling)

Control data record

A control data record 196 is defined for the configuration control that receives a slot assignment.

Table 4- 3 Control data record

Byte	Element	Code	Explanation
0	Block length	4 + number of slots	Header
1	Block ID	196	
2	Version	3	
3	Version	0	
4	Assignment of configured slot 0	Real slot 0	Control element Describes in each element which real slot in the device is assigned to the configured slot.
5	Assignment of configured slot 2	Real slot 2	
:	:	:	
4 + (max. slot - 1)	Assignment of configured maximum slot	Real maximum slot	

Control element

Each element must include the following information about the slot:

- Assignment of configured slot ↔ real slot

Table 4- 4 Code of control element

Byte	Bit	Meaning
Assignment of configured slot (e.g. in byte 5)	0 to 7	01111111: Module not available 00000000 up to maximum slot: Real slot

Special features

Special features you have to observe:

- Configuration control is controlled by the interface module (slot 1/submodule 1). To address the available data records:
 - In STEP 7 V5.5: use the diagnostic address of the interface module.
You can find it in the properties **header** of the interface module in the hardware configuration.
 - In STEP 7 (TIA Portal): use the HW ID of the interface module.
You can find it in the **PLC tags > Default tag table > System constants**. The default name is "IM155-5PN[Head]". Use the associated "value" for addressing.
You can find general information on writing a data record, for example, in the STEP 7 online help.
- The control data record is saved retentively in the interface module, so that it is not necessary to write the control data record 196 again at a restart if the configuration is unchanged.
- Slot entries outside the configured preset configuration are ignored.
- The control data record can be shortened. It must contain the entries up to the last slot of the current preset configuration.
- Each real slot may only exist once in the data record.
- A real slot may only be assigned to one configured slot.
- Power supply (PS) modules can also be subject to configuration control. Make sure to observe the information on maximum configuration (Page 12) and the section on the power budget in the system manual S7-1500, ET 200MP Automation system (<https://support.industry.siemens.com/cs/ww/en/view/59191792>). Particularly for a power supply (PS) module on slot 0, we recommend that you avoid reconfiguration.

Note

Modified configuration

When you write a control data record with modified configuration, there is a station failure followed by a restart of the station with the modified configuration.

Combination of configuration control and Shared Device

The configuration control function in a Shared Device is therefore only for the modules of the IO controller that has subscribed to the interface module.

Modules that are assigned to another IO controller or not assigned at all cannot be specified as real slots (Shared Device on module level). A one-to-one assignment is implicitly assumed for the modules.

If a module intended for configuration control is subscribed by additional controllers (Shared Device on submodule level), only a one-to-one assignment is permitted for this module. Such a module cannot be deselected by the control data record (0x7F code for this slot in the control data record). This means the combination of "Configuration control" and "Shared Device on submodule level" is possible to a limited extent.

Error messages

The following error messages are returned if an error occurs during writing of the control data record:

Table 4- 5 Error messages

Error code	Meaning
80B1 _H	Invalid length
80B5 _H	Configuration control not configured
80B6 _H	Data record does not originate from the IO controller which subscribed to the interface module
80B8 _H	Parameter error

A parameter error may be caused by:

- Incorrect block ID in the header (not equal to 196)
- Invalid version identification in the header
- A reserve bit was set
- A configured slot was assigned to an invalid real slot (see section **Combination of configuration control and Shared Device**)
- Several configured slots refer to the same real slot
- With Shared Device on submodule level: Violation of defined restrictions (see section **Combination of configuration control and Shared Device**)

4.3.2 Feedback data record

Feedback data record

The feedback data record provides information on the accuracy of the module assignment and gives you the chance to detect assignment errors in the control data record. The feedback data record is mapped by a separate data record 197.

The feedback data record exists only when configuration control is configured and always refers to the maximum quantity framework **without interface module**, i.e., 31 slots.

The following applies here:

- The power supply (PS) module is inserted in "Slot 0" **before** the interface module
- Starting from "Slot 2", a maximum of 30 modules follow **after** the interface module.

Partial reading of the feedback data record is possible.

Table 4- 6 Feedback data record

Byte	Element	Code	Meaning
0	Block length	66	Header
1	Block ID	197	
2	Version	2	
3		0	
4	Slot 0 status	0/1	Bit 0 = 1:
5	Reserved	0	<ul style="list-style-type: none"> • Configured module is inserted
6	Slot 2 status	0/1	<ul style="list-style-type: none"> • Slot is marked as not available in the control data record
7	Reserved	0	Bit 0 = 0:
:	:	:	
64	Slot n status	Maximum slot	<ul style="list-style-type: none"> • Module pulled
65	Reserved	0	<ul style="list-style-type: none"> • Wrong module inserted*
			Bits 1 to 15: Reserved

* Not possible if the slot is marked as not available.

Note

The data in the feedback data record are always mapped for all modules. In a Shared Device configuration it is therefore irrelevant which controller the respective modules are assigned to.

As long as no control data record was sent, a one-to-one module assignment is assumed for the compilation of data record 197 (preset configuration → actual configuration).

Error messages

The following error messages are returned if an error occurs during reading of the feedback data record:

Table 4-7 Error messages

Error code	Meaning
80B1H	Invalid length
80B5H	Configuration control not configured
80B8H	Parameter error

4.3.3 Configure configuration control without empty slots

Operating principle

The modules actually not required do not exist. The configuration is pushed together to the left in the direction of IM 155-5 PN HF.

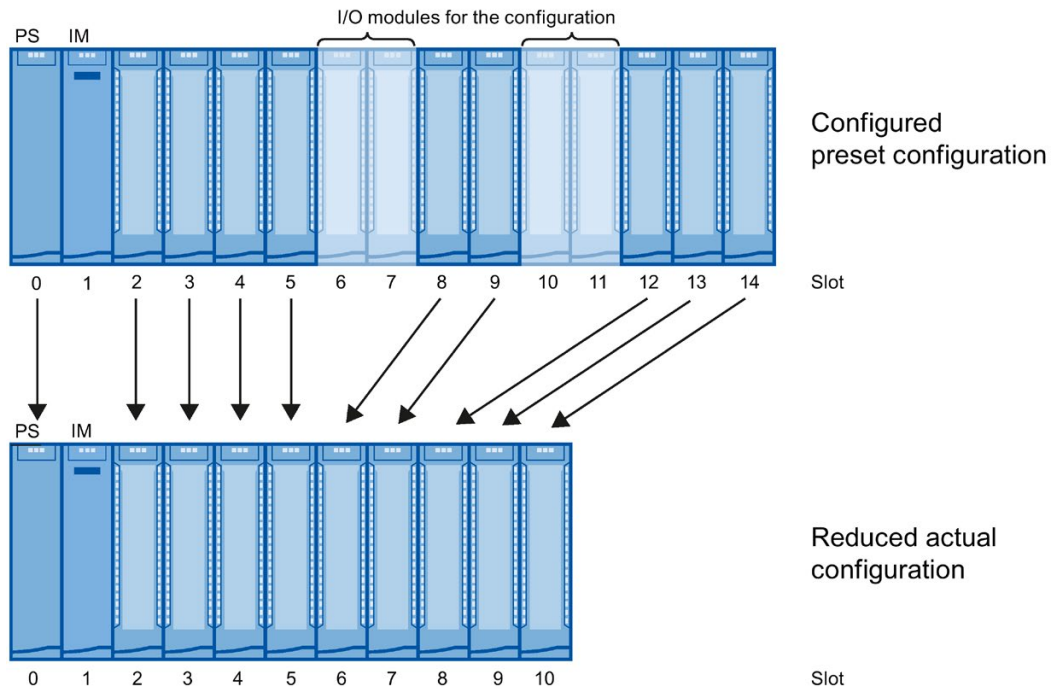

Figure 4-1 Configure configuration control without empty slots

Data record of the example

The following table shows the structure of the control data record for the above example.

Table 4- 8 Data record for example "Configure configuration control without empty slots"

Byte	Element	Code	Explanation
0	Block length	18	Header
1	Block ID	196	
2	Version	3	
3	Version	0	
4	Slot 0	00000000 _B	The configured slot 0 is the real slot 0.
5	Slot 2	00000010 _B	The configured slot 2 is the real slot 2.
6	Slot 3	00000011 _B	The configured slot 3 is the real slot 3.
7	Slot 4	00000100 _B	The configured slot 4 is the real slot 4.
8	Slot 5	00000101 _B	The configured slot 5 is the real slot 5.
9	Slot 6	01111111 _B	The configured slot 6 does not exist.
10	Slot 7	01111111 _B	The configured slot 7 does not exist.
11	Slot 8	00000110 _B	The configured slot 8 is the real slot 6.
12	Slot 9	00000111 _B	The configured slot 9 is the real slot 7.
13	Slot 10	01111111 _B	The configured slot 10 does not exist.
14	Slot 11	01111111 _B	The configured slot 11 does not exist.
15	Slot 12	00001000 _B	The configured slot 12 is the real slot 8.
16	Slot 13	00001001 _B	The configured slot 13 is the real slot 9.
17	Slot 14	00001010 _B	The configured slot 14 is the real slot 10.

4.3.4 Extending the configuration

Operating principle

You can add modules at the end of the configuration with this procedure. The configured configuration can also be extended from the center based on freely selectable slot assignment.

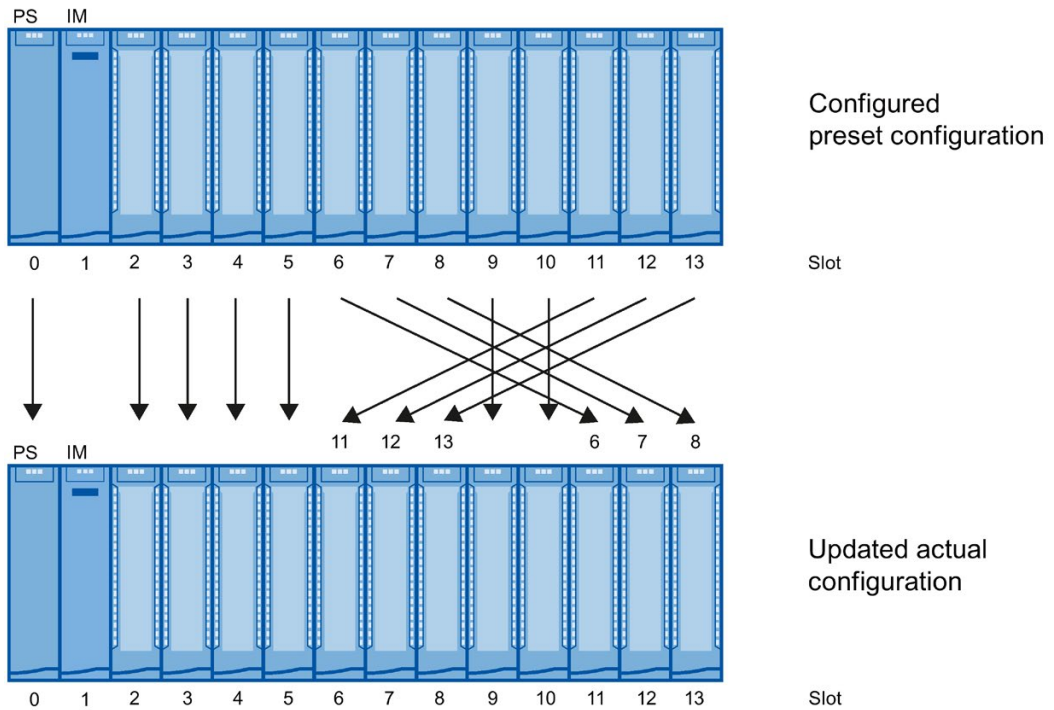

Figure 4-2 Extending the configuration

Data record of the example

The following table shows the structure of the control data record for the above example.

Table 4- 9 Data record for example "Extending the configuration"

Byte	Element	Code	Explanation
0	Block length	17	Header
1	Block ID	196	
2	Version	3	
3	Version	0	
4	Slot 0	00000000 _B	The configured slot 0 is the real slot 0.
5	Slot 2	00000010 _B	The configured slot 2 is the real slot 2.
6	Slot 3	00000011 _B	The configured slot 3 is the real slot 3.
7	Slot 4	00000100 _B	The configured slot 4 is the real slot 4.
8	Slot 5	00000101 _B	The configured slot 5 is the real slot 5.
9	Slot 6	00001011 _B	The configured slot 6 is the real slot 11.
10	Slot 7	00001100 _B	The configured slot 7 is the real slot 12.
11	Slot 8	00001101 _B	The configured slot 8 is the real slot 13.
12	Slot 9	00001001 _B	The configured slot 9 is the real slot 9.
13	Slot 10	00001010 _B	The configured slot 10 is the real slot 10.
14	Slot 11	00000110 _B	The configured slot 11 is the real slot 6.
15	Slot 12	00000111 _B	The configured slot 12 is the real slot 7.
16	Slot 13	00001000 _B	The configured slot 13 is the real slot 8.

4.3.5 Combining configurations

Operating principle

You can combine the different procedures with configuration control.

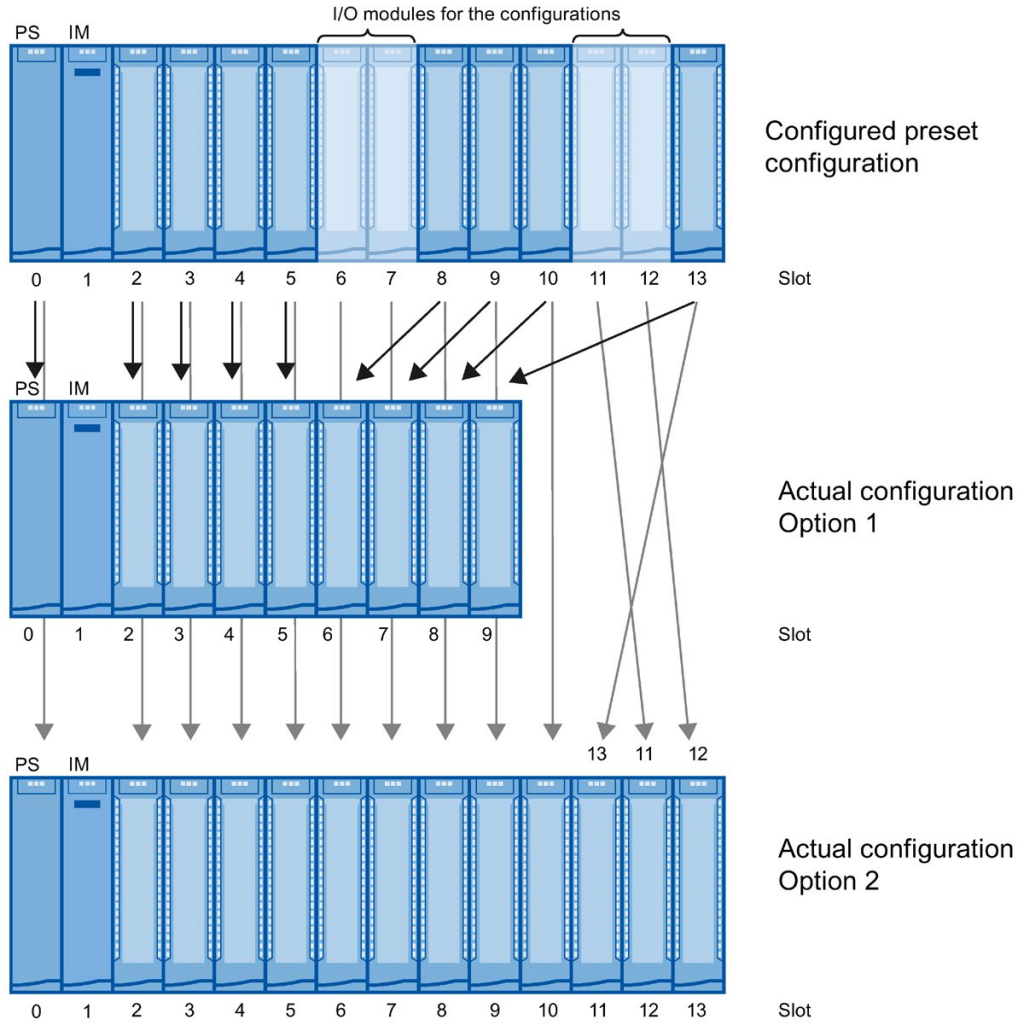

Figure 4-3 Combining configurations

Data record of the example

The following table shows the structure of the control data record for the above example.

Table 4- 10 Data record for example "Combining configurations"

Byte	Element	Code configura- tion 1	Code configura- tion 2	Explanation
0	Block length	17		Header
1	Block ID	196		
2	Version	3		
3	Version	0		
4	Slot 0	00000000 _B	00000000 _B	The configured slot 0 is the real slot 0.
5	Slot 2	00000010 _B	00000010 _B	The configured slot 2 is the real slot 2.
6	Slot 3	00000011 _B	00000011 _B	The configured slot 3 is the real slot 3.
7	Slot 4	00000100 _B	00000100 _B	The configured slot 4 is the real slot 4.
8	Slot 5	00000101 _B	00000101 _B	The configured slot 5 is the real slot 5.
9	Slot 6	01111111 _B	00000110 _B	The configured slot 6 does not exist (configuration 1). The configured slot 6 is the real slot 6 (configuration 2).
10	Slot 7	01111111 _B	00000111 _B	The configured slot 7 does not exist (configuration 1). The configured slot 7 is the real slot 7 (configuration 2).
11	Slot 8	00000110 _B	00001000 _B	The configured slot 8 is the real slot 6 (configuration 1). The configured slot 8 is the real slot 8 (configuration 2).
12	Slot 9	00000111 _B	00001001 _B	The configured slot 9 is the real slot 7 (configuration 1). The configured slot 9 is the real slot 9 (configuration 2).
13	Slot 10	00001000 _B	00001010 _B	The configured slot 10 is the real slot 8 (configuration 1). The configured slot 10 is the real slot 10 (configuration 2).
14	Slot 11	01111111 _B	00001100 _B	The configured slot 11 does not exist (configuration 1). The configured slot 11 is the real slot 12 (configuration 2).
15	Slot 12	01111111 _B	00001101 _B	The configured slot 12 does not exist (configuration 1). The configured slot 12 is the real slot 13 (configuration 2).
16	Slot 13	00001001 _B	00001011 _B	The configured slot 13 is the real slot 9 (configuration 1). The configured slot 13 is the real slot 11 (configuration 2).

Interrupts and diagnostic, error, and system alarms

5.1 Status and error displays

Introduction

Diagnostics by means of LED display is an initial tool for error localization. To narrow down the error, you usually evaluate the display of the CPU, the display of the module status in STEP 7 or the diagnostics buffer of the CPU. The buffer contains plain text information on the error that has occurred. For example, you will find the number of the appropriate error OB there.

LED display

The figure below shows the LED display on the IM 155-5 PN HF interface module.

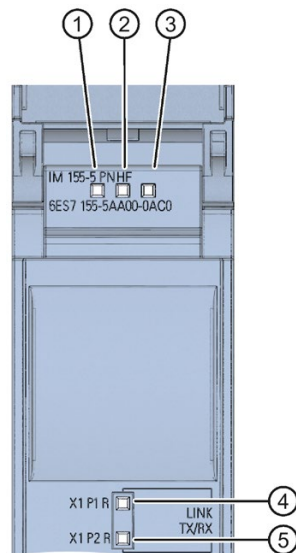

- ① RUN (green)
- ② ERROR (red)
- ③ MAINT (yellow)
- ④ P1 LINK/TX/RX (green/yellow)
- ⑤ P2 LINK/TX/RX (green/yellow)

Figure 5-1 LED display on the interface module

Meaning of the LEDs RUN/ ERROR/ MAINT





Table 5- 1 Meaning of the LEDs RUN/ ERROR/ MAINT

LEDs			Meaning	Remedy
RUN	ERROR	MAINT		
□ Off	□ Off	□ Off	Supply voltage not present or too low at interface module	Check the supply voltage or turn it on at the interface module.
■ On	■ On	■ On	Test of LEDs during startup: The three LEDs light up simultaneously for approximately 0.25 s.	---
⚡ Flashes	□ Off	□ Off	Interface module is deactivated.	Activate the interface module with the configuration software or the user program.
			Interface module is not configured.	Configure the interface module with the configuration software.
			ET 200MP is starting up.	---
			ET 200MP is being reset to factory settings.	---
■ On	Not relevant	Not relevant	ET 200MP is currently exchanging data with the IO controller.	
Not relevant	⚡ Flashes	Not relevant	Group error and group error channels	Evaluate the diagnostics and correct the error.
			The set configuration does not correspond to the actual configuration of the ET 200MP.	Check the configuration of the ET 200MP to see whether a module is missing or defective, or whether a non-configured module is inserted.
			Invalid configuration states	See section Invalid configuration states of the ET 200MP on PROFINET IO (Page 47)
			Parameter assignment error in the I/O module	Evaluate the display of the module status in STEP 7 and correct the error in the corresponding I/O module.
Not relevant	Not relevant	■ On	Maintenance	See section Maintenance events (Page 42)
⚡ Flashes	⚡ Flashes	⚡ Flashes	"Node flash test" is being performed. (The LEDs P1 and P2 of the PROFINET interface are also flashing.)	---
			Hardware or firmware defective. (The LEDs P1 and P2 of the PROFINET interface are not flashing.)	Run a firmware update. If the error persists, contact Service & Support. Replace the interface module.

5.2 Interrupts

Meaning of the LEDs P1 LINK/TX/RX, P2 LINK/TX/RX

Table 5- 2 Meaning of the LEDs P1 LINK/TX/RX, P2 LINK/TX/RX

LEDs P1 LINK/TX/RX, P2 LINK/TX/RX	Meaning	Remedy
 Off	There is no Ethernet connection between the PROFINET interface of your PROFINET device and a communication partner (e.g. IO controller).	Check whether the bus cable to the switch/IO controller is interrupted.
 On	There is an Ethernet connection between the PROFINET interface of your PROFINET device and a communication partner (e.g., IO controller).	---
 Flickers	There is active data traffic (sending/receiving) via the Ethernet connection.	---
 Flashes	"Node flash test" is being performed. (The LEDs RUN/ ERROR/ MAINT are also flashing.)	---

5.2 Interrupts

Introduction

The I/O device generates interrupts as a reaction to specific error events. Interrupts are evaluated based on the I/O controller used.

Evaluating interrupts with I/O controllers

The ET 200MP distributed I/O system supports the following interrupts:

- Diagnostic interrupts
- Hardware interrupts

In the event of an interrupt, interrupt OBs are automatically called in the CPU of the IO controller.

Information on the cause and class of the error is already available, based on the OB number and start information.

Detailed information on the error event can be obtained in the error OB using the instruction "RALRM" (read additional interrupt information).

System diagnostics

In STEP 7 (TIA Portal) as of V12, innovative system diagnostics is available for devices of the S7-1500 automation system and ET 200MP. Independently of the cyclical user program, alarms are made available on the display of the S7-1500 CPU, to the S7-1500 CPU web server, to the HMI device and in STEP 7.

For additional information on the system diagnostics, refer to the System diagnostics function manual (<http://support.automation.siemens.com/WW/view/en/59192926>).

5.2.1 Triggering of a diagnostic interrupt

Triggering of a diagnostic interrupt

For an incoming or outgoing event (e.g., wire break on a channel of an I/O module), the module triggers a diagnostic interrupt if this is configured accordingly in STEP 7 (TIA Portal).

The CPU interrupts user program execution and executes the diagnostic interrupt OB. The event that triggered the interrupt is entered in the start information of the diagnostic interrupt OB.

5.2.2 Triggering of a hardware interrupt

Triggering of a hardware interrupt

When a hardware interrupt occurs, the CPU interrupts execution of the user program and processes the hardware interrupt OB. The event that triggered the interrupt is entered in the start information of the hardware interrupt OB.

Note

Diagnostics "Hardware interrupt lost" (from I/O module)

Avoid creating hardware interrupts cyclically.

If the hardware interrupt load is too high, hardware interrupts can get lost depending on the number of I/O modules and the communication load.

5.3 Alarms

5.3.1 Diagnostic alarms

Actions after a diagnostic alarm

There can be more than one diagnostic alarm at the same time. Each diagnostic alarm initiates the following actions:

- The ERROR LED of the interface module flashes.
- Diagnostics are reported as diagnostic interrupts to the CPU of the IO controller and can be read via data records.
- Incoming diagnostic alarms are saved to the diagnostic buffer of the IO controller.
- The diagnostic interrupt OB is called. If the diagnostic interrupt OB is not available, the IO controller goes into STOP mode.

You can find additional information in the STEP 7 online help.

Reading out the diagnostics

Table 5- 3 Reading out the diagnostics with STEP 7

Automation system with IO controller	Application	See...
SIMATIC S7	Diagnostics as plain text in STEP 7 using online view and diagnostic view	Online help of STEP 7 and <ul style="list-style-type: none"> • As of STEP 7 V12 PROFINET with STEP 7 V12 function manual (http://support.automation.siemens.com/WW/view/en/948856) • As of STEP 7 V5.5 PROFINET System Description (http://support.automation.siemens.com/WW/view/en/19292127) manual.
	Instruction "RDREC" Read data records from the IO device	
	Instruction "RALRM" Receive interrupts from the IO device	

Additional information on the data records for PROFINET IO

You can find the structure of the diagnostic data records and programming examples in the programming manual From PROFIBUS DP to PROFINET IO (<http://support.automation.siemens.com/WW/view/en/19289930>) and in the application example on the Internet (<http://support.automation.siemens.com/WW/view/en/24000238>).

Causes of error and corrective measures

The error causes and corrective measures of the diagnostic alarms are described in the manuals for the I/O modules (<http://support.automation.siemens.com/WW/view/en/67296522/133300>) in the Interrupts/Diagnostic alarms section.

See also

Channel diagnostics (Page 43)

5.3.2 Maintenance events

Triggering of a maintenance event

The PROFINET interface of the interface module supports the diagnostic concept and maintenance concept in PROFINET according to the IEC 61158-6-10 standard. The goal is to detect and remove potential problems as soon as possible.

For the interface module, maintenance events signal to the user when a network component must be checked or replaced.

The CPU interrupts user program execution and executes the diagnostic interrupt OB. The event that triggered the maintenance event is entered in the start information of the diagnostic interrupt OB.

The interface module signals a maintenance event to the higher-level diagnostic system in the case of the following events:

Table 5- 4 Triggering of a maintenance event

Maintenance alarm	Event	Meaning
Maintenance demanded MAINT LED is lit	Synchronization loss	<ul style="list-style-type: none"> No synchronization frame received No synchronization frame was received by the sync master within the timeout period after parameter assignment or during operation. <ul style="list-style-type: none"> Successive synchronization frames are located outside permitted limits (jitter)
	Maintenance event of an I/O module	The maintenance event of a power supply module is passed through.

System alarms in STEP 7

The maintenance information is generated in STEP 7 with the following system alarms:

- Maintenance demanded - indicated for each port by a yellow wrench icon  in the device view or in the hardware configuration.

You can find additional information in the STEP 7 online help.

5.3.3 Channel diagnostics

Function

Channel diagnostics provides information about channel faults in modules.

Channel faults are mapped as channel diagnostics in IO diagnostic data records.

The "RDREC" instruction is used to read the data record.

Structure of the diagnostic data records

- As of firmware version V4.2: The IM 155-5 PN HF interface module maps channel faults by means of extended channel diagnostics.

The data records supported by the ET 200MP are based on the standard PROFINET IO - Application Layer Service Definition V2.3.

- Firmware version lower than V4.2: The IM 155-5 PN HF interface module maps channel faults by means of manufacturer-specific diagnostic data records.

The data records are based on the PROFINET IO standard - Application Layer Service Definition V2.2.

You can purchase the standards from the PROFIBUS User Organization on the Internet (<http://www.profibus.com>).

Coding of the extended channel diagnostics (as of firmware version V4.2)

With the IM 155-5 PN HF interface module, the following extended channel diagnostics are reported by the interface module in slot 1:

Table 5- 5 Manufacturer-specific diagnostics in the USI

ChannelError-Type	ExtendedChannel ErrorType	Associated value (AddValue)	Diagnostics
0x0601	0x0682	Slot	Communication with slot <No.> has failed
0x0602	0x0692	Slot	Permitted number of I/O modules exceeded
0x0602	0x069B	Slot	Permitted number of power supply modules exceeded
0x0602	0x0696	0	No U connector detected on an IM port
0x0602	0x0697	0	More than one bus master module (IM/CPU) detected
0x0610	0x06B1	Slot	Power budget error (overload has been detected in at least one power segment)
0x0610	0x06B2	0	Error IM power supply: Power supply not active or power supply active

Structure of the manufacturer-specific diagnostic data records (firmware version lower than V4.2)

The structure of the diagnostic data records is differentiated by the BlockVersion. The following BlockVersion applies to the IM 155-5 PN HF interface modules:

Table 5- 6 Structure of the manufacturer-specific diagnostic data records

IM 155-5 PN HF interface module	BlockVersion
6ES7155-5AA00-0AC0	W#16#0101

Manufacturer-specific diagnostics in the User Structure Identifier (USI)

The following manufacturer-specific diagnostics are signaled in the USI with the IM 155-5 PN HF interface module:

Table 5- 7 Manufacturer-specific diagnostics in the USI

USI no. W#16#...	Diagnostics
0001	Power budget error (overload has been detected in at least one power segment)
0002	Permitted number of power supply modules exceeded
0003	Permitted number of I/O modules exceeded
0004	No U connector detected on an IM port
0005	More than one bus master module (IM/CPU) detected
0006	Communication with slot <No.> has failed
0007	Error IM power supply: Power supply not active or power supply active

Additional information

You can find additional information on maximum configuration, power budget and power segments in the system manual S7-1500, ET 200MP Automation system (<https://support.industry.siemens.com/cs/ww/en/view/59191792>).

Structure USI = W#16#0001

Table 5- 8 Structure of USI = W#16#0001

Data block name	Contents	Note	Bytes
USI	W#16#0001	Manufacturer-specific diagnostics in case of overload in an ET 200MP power segment	2
Followed by 3 reserved bytes			
	Reserved		1
	Reserved		1
	Reserved		1
The first power segment with overload starts at slot: <No.>			
Slot	B#16#00 to B#16#1F		1

Structure USI = W#16#0002

Table 5- 9 Structure of the USI = W#16#0002

Data block name	Contents	Note	Bytes
USI	W#16#0002	Manufacturer-specific diagnostics if the permitted number of power supply modules is exceeded	2
Followed by 3 reserved bytes			
	Reserved		1
	Reserved		1
	Reserved		1
The first surplus module is located in slot: <No.>			
	Slot	B#16#00 to B#16#1F	1

USI structure = W#16#0003

Table 5- 10 USI structure = W#16#0003

Data block name	Contents	Note	Bytes
USI	W#16#0003	Manufacturer-specific diagnostics if the permitted number of I/O modules is exceeded	2
Followed by 3 reserved bytes			
	Reserved		1
	Reserved		1
	Reserved		1
The first surplus module is located in slot: <No.>			
	Slot	B#16#20 to B#16#FF	1

USI structure = W#16#0004

Table 5- 11 USI structure = W#16#0004

Data block name	Contents	Note	Bytes
USI	W#16#0004	Manufacturer-specific diagnostics if no U connector is detected on an IM port	2
Followed by 4 reserved bytes			
	Reserved		1
	Reserved		1
	Reserved		1
	Reserved		1

5.3 Alarms

USI structure = W#16#0005

Table 5- 12 USI structure = W#16#0005

Data block name	Contents	Note	Bytes
USI	W#16#0005	Manufacturer-specific diagnostics if there is more than one bus master module (IM/CPU)	2
Followed by 4 reserved bytes			
	Reserved		1
	Reserved		1
	Reserved		1
	Reserved		1

USI structure = W#16#0006

Table 5- 13 USI structure = W#16#0006

Data block name	Contents	Note	Bytes
USI	W#16#0006	Manufacturer-specific diagnostics if the communication with a slot has failed	2
Followed by 3 reserved bytes			
	Reserved		1
	Reserved		1
	Reserved		1
Communication has failed with slot: <No.>			
	Slot	B#16#00 to B#16#1F	1

USI structure = W#16#0007

Table 5- 14 USI structure = W#16#0007

Data block name	Contents	Note	Bytes
USI	W#16#0007	Manufacturer-specific diagnostics if the configuration of the interface module power supply is different from the parameterized configuration	2
Followed by 3 reserved bytes			
	Reserved		1
	Reserved		1
	Reserved		1
Error IM power supply: Power supply <bit 0 in the least significant byte can be 0 or 1>			
Power supply of the interface module	B#16#00	Power supply of the interface module is not active.	1
	B#16#01	Power supply of the interface module is active.	

5.3.4 Invalid configuration states of the ET 200MP on PROFINET IO**Invalid configuration states**

The following invalid configuration states of the ET 200MP lead to a short failure of the ET 200MP IO device or prevent the exchange of user data with the I/O modules.

- More than two power supply modules (PS) inserted to the right of the interface module
- Number of modules exceeds maximum configuration
- Faulty backplane bus (e.g., additional IM present).
- I/O modules of a power segment consume more power than can be provided (overload). In the case of an overload, the interface module provides diagnostic information, cyclically checks the connection to the backplane bus and re-establishes it as soon as possible.

Additional information

You can find additional information on maximum configuration, power budget and power segments in the system manual S7-1500, ET 200MP Automation system (<https://support.industry.siemens.com/cs/ww/en/view/59191792>).

See also:

Status and error displays (Page 36)

5.3.5 STOP of the IO controller and recovery of the IO device

STOP of the SIMATIC IO controller

Diagnostics received from the IO device while the IO controller is in STOP state do not initiate a call of the corresponding OBs when the IO controller starts up. You have to read the data record E00C_H using the "RDREC" instruction in the startup OB. This record contains all diagnostics for the slots assigned to an IO controller in an IO device.

Recovery of the SIMATIC IO device

If you want to read the diagnostics that occurred in the STOP state of the IO controller, you have to read the E00C_H data record using the "RDREC" instruction. This record contains all diagnostics for the slots assigned to an IO controller in an IO device.

Technical specifications

Technical specifications of the IM 155-5 PN HF

Article number	6ES7155-5AA00-0AC0
General information	
Product type designation	IM 155-5 PN HF
HW functional status	FS03
Firmware version	V4.2
<ul style="list-style-type: none"> FW update possible 	Yes
Vendor identification (VendorID)	002AH
Device identifier (DeviceID)	0X0312
Product function	
<ul style="list-style-type: none"> I&M data 	Yes; I&M0 to I&M3
Engineering with	
<ul style="list-style-type: none"> STEP 7 TIA Portal configurable/integrated as of version 	V13 / V13
<ul style="list-style-type: none"> STEP 7 configurable/integrated as of version 	V5.5 SP3 / -
<ul style="list-style-type: none"> PROFINET as of GSD version/GSD revision 	V2.3 / -
Configuration control	
via user data	No
via dataset	Yes
Supply voltage	
Rated value (DC)	24 V
permissible range, lower limit (DC)	20.4 V
permissible range, upper limit (DC)	28.8 V
Reverse polarity protection	Yes
Short-circuit protection	Yes
Mains buffering	
<ul style="list-style-type: none"> Mains/voltage failure stored energy time 	5 ms
Input current	
Current consumption (rated value)	0.2 A
Current consumption, max.	1.2 A
Inrush current, max.	9 A
I^2t	0.09 A ² ·s

Article number	6ES7155-5AA00-0AC0
Power	
Infeed power to the backplane bus	14 W
Power available from the backplane bus	2.3 W
Power loss	
Power loss, typ.	4.5 W
Address area	
Address space per module	
• Address space per module, max.	256 byte; per input / output
Address space per station	
• Address space per station, max.	512 byte; per input / output
Hardware configuration	
Integrated power supply	Yes
System power supply can be plugged in to left of IM	Yes
Number of permissible power segments	3
Rack	
• Modules per rack, max.	30; I/O modules
Submodules	
• Number of submodules per station, max.	256
Interfaces	
Number of PROFINET interfaces	1
1. Interface	
Interface types	
• Number of ports	2
• integrated switch	Yes
• RJ 45 (Ethernet)	Yes
Protocols	
• PROFINET IO Device	Yes
• Media redundancy	Yes
Interface types	
RJ 45 (Ethernet)	
• Transmission procedure	PROFINET with 100 Mbit/s full duplex (100BASE-TX)
• 100 Mbps	Yes
• Autonegotiation	Yes
• Autocrossing	Yes
Protocols	
PROFINET IO Device	
Services	
– Isochronous mode	Yes

Article number	6ES7155-5AA00-0AC0
<ul style="list-style-type: none"> – IRT – PROFINET – Prioritized startup – Shared device – Number of IO Controllers with shared device, max. 	Yes No Yes Yes 4
Redundancy mode	
<ul style="list-style-type: none"> – MRP – MRPD – PROFINET system redundancy (S2) – Redundant PROFINET configuration (R1) – H-Sync forwarding 	Yes Yes Yes No Yes
Open IE communication	
<ul style="list-style-type: none"> • TCP/IP • SNMP • LLDP 	Yes Yes Yes
Isochronous mode	
Isochronous operation (application synchronized up to terminal)	Yes
Equidistance	Yes
shortest clock pulse	250 µs
max. cycle	4 ms
Interrupts/diagnostics/status information	
Status indicator	Yes
Alarms	Yes
Diagnostics function	Yes
Diagnostics indication LED	
<ul style="list-style-type: none"> • RUN LED • ERROR LED • MAINT LED • Connection display LINK TX/RX 	Yes; Green LED Yes; Red LED Yes; yellow LED Yes; yellow LED
Potential separation	
between backplane bus and electronics	No
between PROFINET and all other circuits	Yes; 1500 V AC
between supply and all other circuits	No
Isolation	
Isolation tested with	707 V DC (type test)

Article number	6ES7155-5AA00-0AC0
Ambient conditions	
Ambient temperature during operation	
• horizontal installation, min.	0 °C
• horizontal installation, max.	60 °C
• vertical installation, min.	0 °C
• vertical installation, max.	40 °C
Altitude during operation relating to sea level	
• Installation altitude above sea level, max.	2 000 mm
Connection method	
ET-Connection	
• via BU/BA Send	No
Dimensions	
Width	35 mm
Height	147 mm
Depth	129 mm
Weights	
Weight, approx.	350 g

Dimension drawing

The dimension drawing of the module on the mounting rail, as well as a dimension drawing with open front panel, are provided in the appendix. Always observe the specified dimensions for installation in cabinets, control rooms, etc.

Dimension drawings of the IM 155-5 PN HF interface module

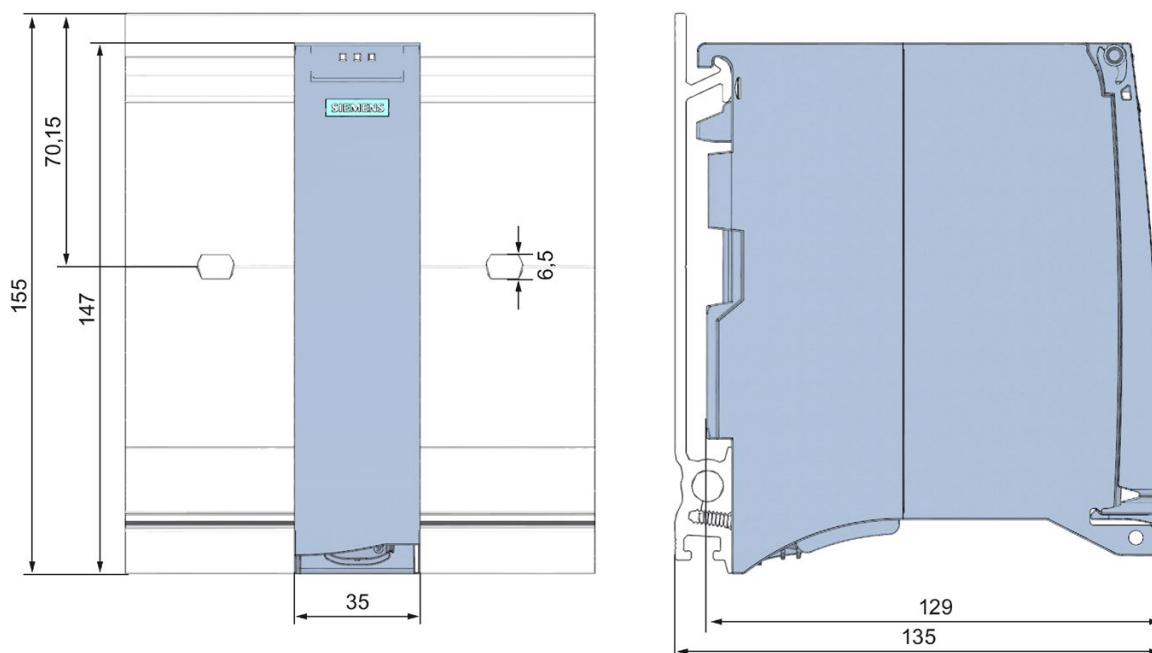

Figure A-1 Dimension drawing of the IM 155-5 PN HF interface module, front and side views

Dimension drawing of the IM 155-5 PN HF interface module, side view with open front cover

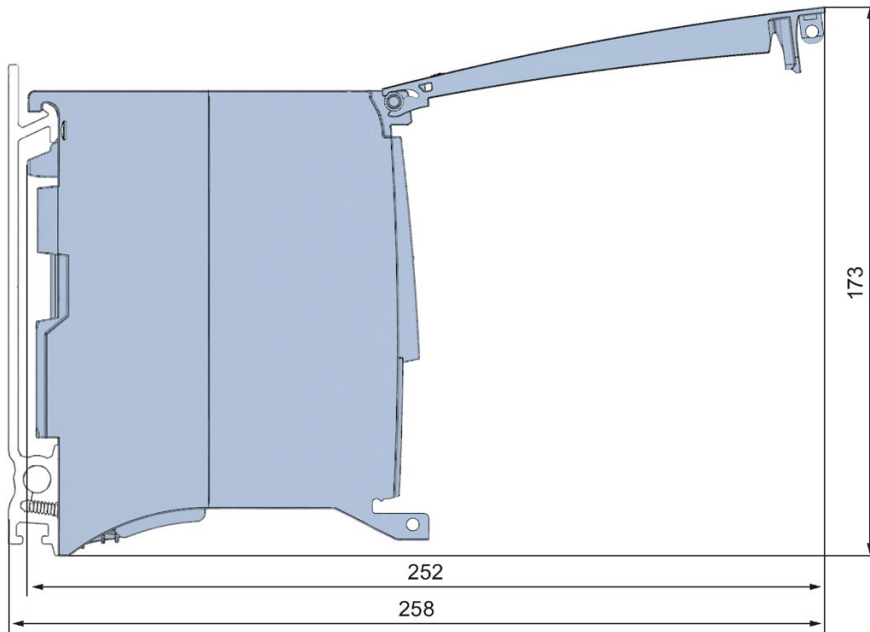

Figure A-2 Dimension drawing of the IM 155-5 PN HF interface module, side view with open front cover

Response times

B.1 Response times of the ET 200MP

Introduction

The response time of the IM 155-5 PN HF is made up of:

- The update time configured for the IM as IO device.

plus

- The backplane bus cycle time.

Note

Validity of the formula

The following formula does not apply to Shared Device mode.

Backplane bus cycle time

The backplane bus cycle time is the time the interface module requires to output new output data, read new input data and then copy them to the PROFINET send buffer.

The backplane bus cycle time in μs is made up as follows:

- $(\text{Number of output data in bytes} + \text{number of output addresses}) \times 0.0668 + 1.6131$
(rounded up)

plus

- $(\text{Number of input data in bytes} + \text{number of input addresses}) \times 0.0959 + 2.5901$
(rounded up)

plus

- Operating system processing time (500 μs).

Example configuration for the calculation of the backplane bus cycle time

The following are used in the example:

Table B- 1 Example configuration for the calculation of the backplane bus cycle time

I/O module	Output data in bytes	Input data in bytes	Number of output addresses	Number of input addresses
Analog output module AQ 4xU/I ST	8	-	1	-
Analog output module AQ 4xU/I ST with value status	8	1	1	1
Digital output module DQ 32x24VDC/0.5A ST with value status	4	4	1	1
Digital input module DI 32x24VDC HF	-	4	-	1
Analog input module AI 8xU/I/RTD/TC ST	-	16	-	1
Sum	20	25	3	4

Example calculation of the backplane bus cycle time

Backplane bus cycle time in μs :

- $(20 + 3) \times 0.0668 + 1.6131 = 3.1495 \approx 4 \mu\text{s}$ (rounded up)

plus

- $(25 + 4) \times 0.0959 + 2.5901 = 5.3712 \approx 6 \mu\text{s}$ (rounded up)

plus

- Operating system processing time $500 \mu\text{s}$

Result of backplane bus cycle time

Backplane bus cycle time = $510 \mu\text{s}$

Calculating the response time

It is necessary to differentiate between two cases when calculating the response time of the IM 155-5 PN HF:

- Case 1: The configured update time is greater than/equal to the backplane bus cycle time.

Then:

Response time in μs = backplane bus cycle time + configured update time

- Case 2: The configured update time is less than the backplane bus cycle time.

Then:

Response time in μs = backplane bus cycle time + (configured update time x (backplane bus cycle time / configured update time)).

If the division of backplane bus cycle time / configured update time does not return an integer without remainder, an additional configured update time must be added next to the integer in the bracket.

Example calculation for case 1: The configured update time is greater than/equal to the backplane bus cycle time.

- Configured update time is, for example, 750 μs
- Backplane bus cycle time = 510 μs

Result of case 1

Response time of the IM 155-5 PN HF = 750 μs + 510 μs = **1260 μs**

Example calculation for case 2: The configured update time is less than the backplane bus cycle time.

- Configured update time is, for example, 500 μs
- Backplane bus cycle time = 510 μs

Result of case 2

Response time of the IM 155-5 PN HF = 510 μs + (500 μs x (510 μs / 500 μs) + 500 μs) = 510 μs + (500 μs x 1 + 500 μs) = 510 μs + 1000 μs = **1510 μs**

Reference

Additional information about performance measurements is available on the Internet (<http://support.automation.siemens.com/WW/view/en/34677186/136000&csplfrm=0&cssw=0&csbinh=5>).